

1-Saddle CNC Lathes

GENOS L2000-e

GENOS L3000-e



1-Saddle CNC Lathes

GENOS L2000-e GENOS L3000-e



High quality, high performance

High rigidity gives machining accuracy and productivity exceeding expectations, with thorough ease of use from the customer's perspective.

Okuma squarely faced the challenge of these expectations from machine shops worldwide in developing the GENOS high quality global machine.

Since its launch in 2010, GENOS has earned an outstanding reputation from customers around the world.

Okuma's GENOS series has evolved at the leading edge of "Monozukuri"* that seeks to balance high quality and low cost, contributing to improved productivity.

* Craftsmanship-based, sustainable manufacturing



GENOS L2000-e



GENOS L2000-e (MY)



GENOS L3000-e



GENOS L3000-e (MY)

Users can select the best specifications for their work

Models with different distances between centers for turning and milling specifications are available. Users can select the best specifications for their workpiece length and shape.

	Spindle	Turret	Tailstock	DBC
GENOS L2000-e (L)	5,000 min ⁻¹ JIS A2-6 15/11 kW (20 min/cont)	V12 turret	MT No. 5 * NC tailstock	290, 500
GENOS L2000-e (M)		V12 VDI multitasking turret		380
GENOS L2000-e (MY)				

* For the GENOS L2000 DBC 290 machine only, the tailstock spec will be MT No. 4.

Photos used in this brochure include optional equipment.

	Spindle	Turret	Tailstock	DBC
GENOS L3000-e (L)	3,800 min ⁻¹ JIS A2-8 22/15 kW (20 min/cont)	V12 turret	MT No. 5 NC tailstock	500, 1,100
GENOS L3000-e (M)		V12 VDI multitasking turret [V12 radial multitasking turret]		450, 1,000
GENOS L3000-e (MY)				450, 1,000

[]: Optional



Stronger, smaller and easier to use.

Stable, high accuracy machining and high productivity from a compact body. The GENOS L delivers what the customer wants from a lathe with high machining capacity and accuracy: better cost performance with maximum ease of use.

Applicable workpieces



Meeting capacity and accuracy requirements with high productivity

An integral motor/spindle is used for low spindle vibration to achieve high accuracy machining. Powerful cutting made possible by highly rigid machine structure that uses a slide guideway in the turret slideway. Fixturing work before machining can also be done easily with an NC tailstock.

Excellent user-friendliness allows operators to concentrate on the work

Machine configuration for good access and ease of maintenance. A separated coolant tank is used to greatly reduce maintenance time and effort. Machine down time is reduced with little chip accumulation for machine cleanliness even during long, continuous operation in mass production.

Okuma's Intelligent Technology reduces operator burden

Thermo Active Stabilizer-Construction (TAS-C) is used to support dimensional stability on a high plane at cycle start and machining restart. With graphic visualization of machining status on Machining Navi (optional), anyone can use the machine and tools to their fullest without difficulty.

Machining dimensional change over time
 GENOS L3000-e actual data
 (ambient temperature: 8°C change)
 $\leq \varnothing 9 \mu\text{m}$

- Machine startup
- Machining restart
- Room temp change

▶ **High dimensional stability**

Meeting capacity and accuracy requirements with high productivity

Achieve a powerful, high-quality machining

The integral motor/spindle provides fast and high output with high machining capacity—at high quality. And Okuma's legendary slide guideways are highly rigid to handle powerful cutting loads that result in high productivity.

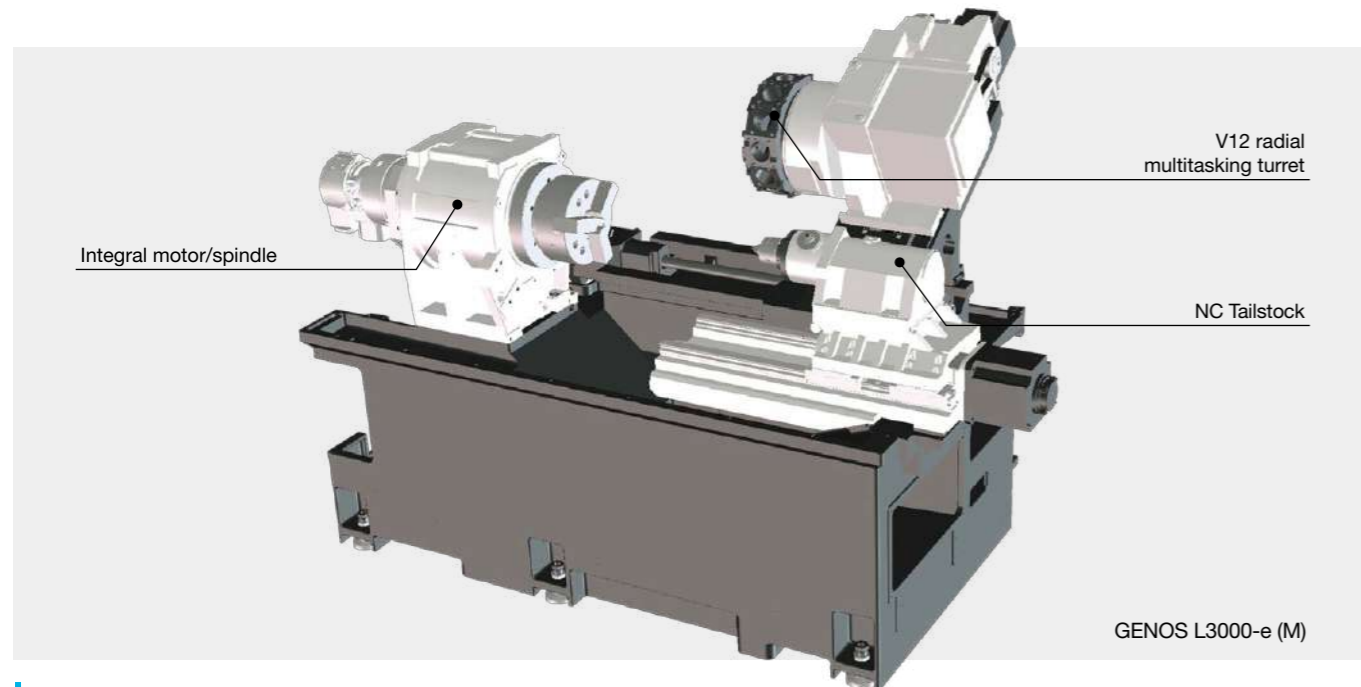

Integral motor/spindle

GENOS L2000-e

- Bearing inside diameter: $\phi 100$ mm
- Through-hole diameter: $\phi 62$ mm
- Spindle speed: 5,000 min^{-1}
- Power: 15/11 kW (20 min/cont)
- Torque: 326/239 N-m (20 min/cont)

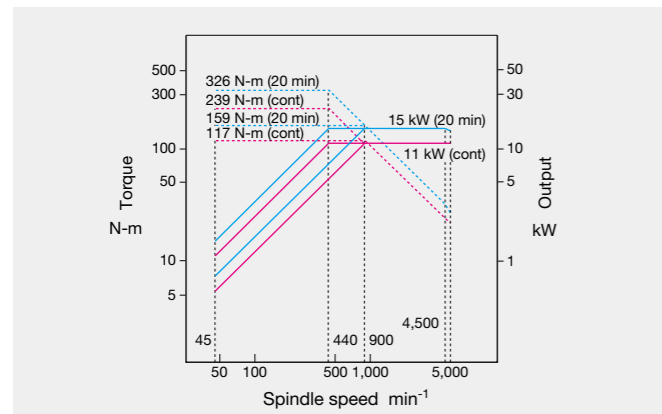

GENOS L3000-e

- Bearing inside diameter: $\phi 120$ mm
- Through-hole diameter: $\phi 80$ mm
- Spindle speed: 3,800 min^{-1}
- Power: 22/15 kW (20 min/cont)
- Torque: 412/281 N-m (20 min/cont)

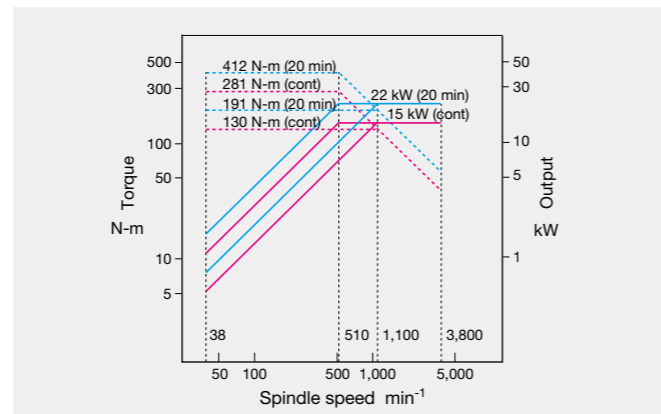

High accuracy milling

Milling tools can be attached to all locations on turrets with milling specifications. With a spindle indexing command of 0.001° , high accuracy milling can be done at any angle. Two types of multitasking turret, VDI and radial, are available on the GENOS L3000-e.



V12 radial multitasking turret (Optional)

Simplified shaft work fixturing

Servomotor control NC tailstock is used for the tailstock. Travel and thrust can be set with program commands, greatly increasing ease of use. Setup change can also be easily done.

Tailstock specifications

	GENOS L2000-e	GENOS L3000-e
Tailstock thrust	1.0–2.0 kN	1.0–5.0 kN
Rapid traverse	12 m/min	12 m/min
Approach	10 m/min	10 m/min
Retract	12 m/min	12 m/min



Milling tool spindle

GENOS L2000-e (M·MY) multitasking V12 VDI turret

- Spindle speed: 6,000 min^{-1}
- Power: 4.0/1.8 kW (25 min/cont)
- Torque: 15.3 N-m

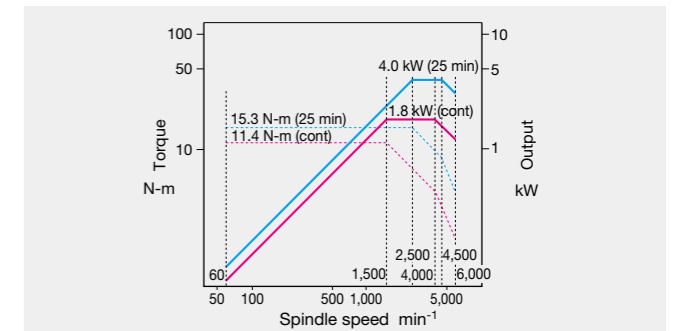

GENOS L3000-e (M·MY) multitasking V12 VDI turret

- Spindle speed: 4,500 min^{-1}
- Power: 7.0/3.3 kW (30 min/cont)
- Torque: 24 N-m

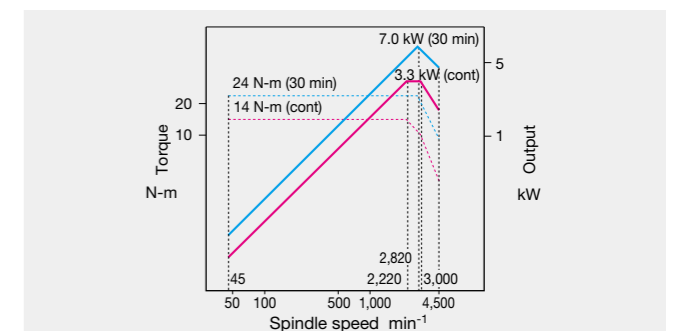

GENOS L3000-e (M·MY) V12 radial multitasking turret (Optional)

- Spindle speed: 6,000 min^{-1}
- Power: 5.5/3.7 kW (2 min/cont)
- Torque: 31 N-m

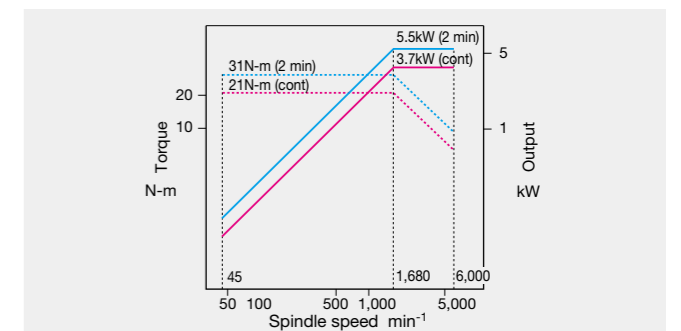

Excellent user-friendliness allows operators to concentrate on the work

Machine designed for good accessibility

Spindle access is good with 372 mm from the machine front face to the spindle center, reducing the work burden of operators.

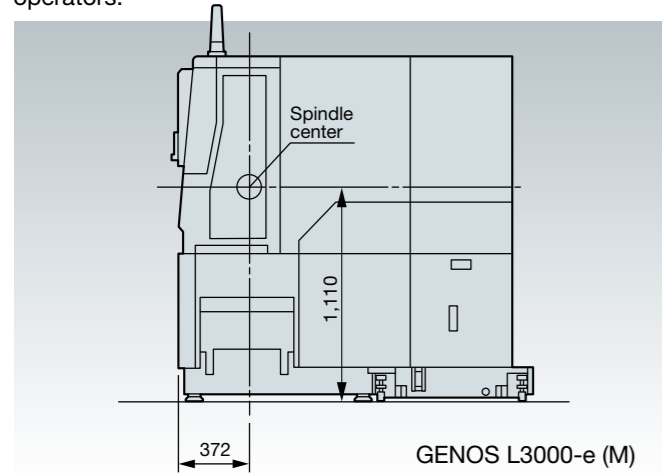

Outstanding chip discharge

The chip discharge outlet is 2 times larger than on previous machines, minimizing chip accumulation. The cleaning frequency is reduced for maximum operation time.

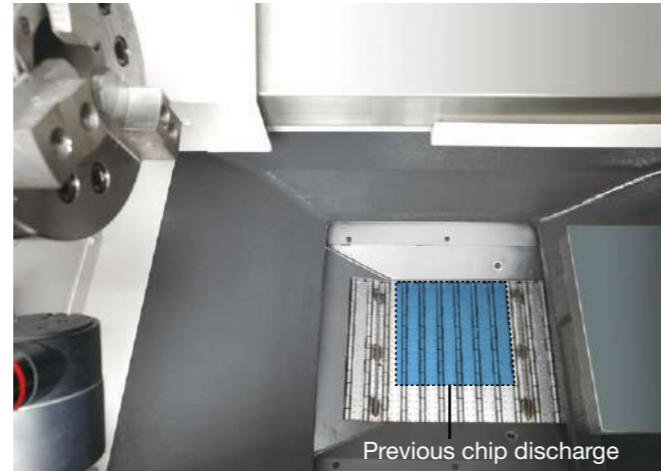

Simplified coolant tank maintenance

The coolant tank can be separated away from the machine for easier cleaning. The tank and the control cabinet share the same maintenance space to minimize the machine footprint.

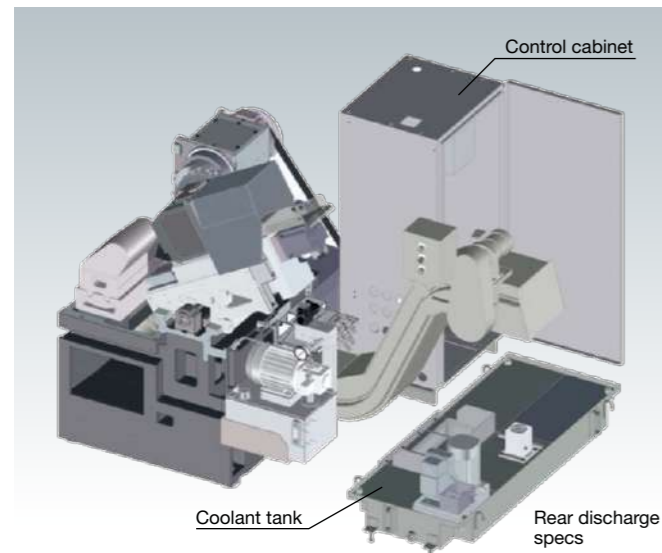

Okuma's Intelligent Technology reduces operator burden



Cutting condition search function for turning Machining Navi L-g (guided, harmonic spindle speed control)

Varying the spindle speed in accordance with the best amplitude and period makes it possible to suppress chatter during turning operations. Tool life can be extended and machining time reduced with use of the optimum cutting conditions, producing significant effects in drilling/boring bar, threading, and grooving applications.

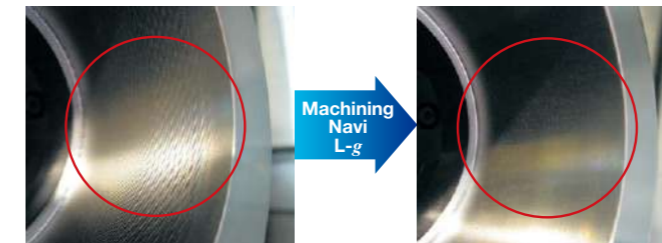
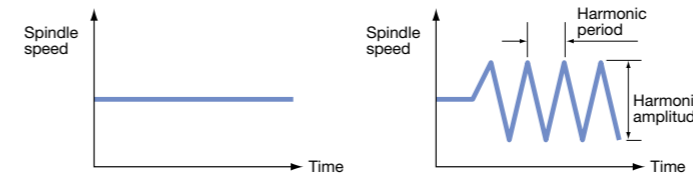

Cutting condition search in threading Machining Navi T-g (threading)

When chatter occurs in threading, general methods to resolve the problem have been to either lower cutting conditions at the expense of productivity, or to use special chatter-resistant tools at some cost. Machining Navi T-g (threading) provides optimum control, increasing or decreasing spindle speed on each pass to inhibit the periodic vibrations that are a cause of chatter.

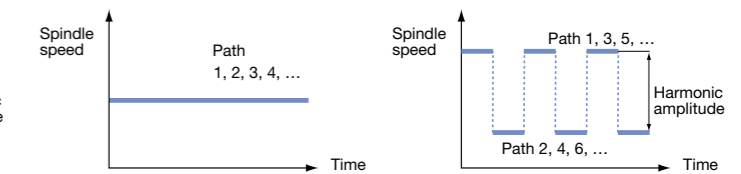

<Normal threading>

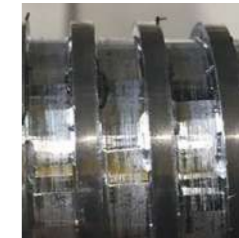

Chatter marks

<Machining Navi T-g>



Smooth surface, clean finished threads

Next-Generation Energy-Saving System

ECO suite

A suite of energy saving applications for machine tools

Operation only for the time required for each unit ECO Idling Stop

Idling time can be set by individual unit for the spindle, feed shaft, and peripheral equipment. By reducing the idling time, power consumption can also be reduced.

- Example of equipment that can use Idling Stop

ECO IDLE STOP			
ECO IDLE STOP ELAPSED TIME 0: 0: 0			
	ECO IDLE STOP	DELAY	
1st Spdl. oil temp. ctrl.	YES	NO	5min
2nd Spdl. oil temp. ctrl.	YES	NO	Immed.
M-spdl. oil temp. ctrl.	YES	NO	Immed.
Hydraulic unit	YES	NO	Immed.
Axis Lubrication unit	YES	NO	Immed.

On-the-spot check of energy savings ECO Power Monitor

Power is shown individually for spindle, feed axes, and auxiliaries on the OSP operation screen. The energy-saving benefits from auxiliary equipment stopped with ECO Idling Stop can be confirmed on the spot.

- Example of Power Monitor check

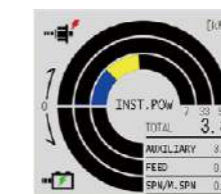

Before ECO Idling Stop



After ECO Idling Stop

The displayed values are one example.

Machine Specifications

Item	Model name	GENOS L2000 (L)			GENOS L2000 (M)	GENOS L2000 (MY)
		T	Cx290	Cx500	Cx380	Cx380
Capacity	Swing over bed	mm	ø450			
	Swing over saddle	mm	ø350			
	Max turning dia	mm	ø230		ø200	
	Max work length	mm	290	500	380	
Travels	X-axis travel	mm	165			
	Z-axis travel	mm	330	470	400	
	Y-axis travel	mm	-			
	C-axis travel	mm	-			80 (+30 to -50)
Spindle	Spindle speed	min ⁻¹	45 to 5,000			
	Speed ranges		2 auto ranges (2 range motor coil switching)			
	Spindle nose type		JIS A2-6			
	Spindle bore dia	mm	ø62			
	Front bearing dia	mm	ø100			
Turret	Type		V12	Multitasking V12 VDI (Axial)		
	No. of tools	tool	12	L and M : 12		
	OD tool shank	mm	25x25		20x20	
	ID tool shank dia	mm	ø40	ø32	ø40	ø32
	Turret indexing time	sec/index	0.3		0.1	
Milling tool	Spindle speed	min ⁻¹	-			50 to 6,000
	Speed range		-			Infinitely variable
Feedrates	Rapid traverse (X, Z, Y)	m/min	X: 25, Z: 30			X: 25, Z: 30, Y: 10
	Rapid traverse (tailstock)	m/min	-	12		-
	Rapid traverse (C)	m/min	-			200
Tailstock	Tapered bore type	mm/rev	-	MT No.4 (revolving center)	MT No.5 (revolving center)	
	Tailstock travel	mm	-	245	420	
Motors	Main spindle	kW	15/11 (20 min/cont)			
	Milling tool spindle	kW	-			4.0/1.8 (25 min/cont)
	Axis drive (X)	kW	3.0			2.8
	Axis drive (Z)	kW	3.0			2.8
	Axis drive (Ys)	kW	-			2.8
	Axis drive (tailstock)	kW	-	1.5	2.9	
	Coolant motor (50/60 Hz)	kW	0.55/0.75			
Machine size	Height	mm	1,620			2,087
	Floor space (tank included)	mmxmm	1,702x1,843	2,015x1,843	2,600x1,832	2,600x1,851
	Weight	kg	3,000	3,200	3,800	3,920
CNC		OSP-P300LA				

[]: Optional

GENOS L3000 (L)			GENOS L3000 (M)			GENOS L3000 (MY)		
T	Cx500	Cx1100	T	Cx450	Cx1000	T	Cx400	Cx1000
			ø520					
			ø400					
ø340			ø300			ø340 [Radial: ø390]		
500	1,100		450 [Radial: 380]	1,060 [Radial: 980]		420 [Radial: 350]	1,020 [Radial: 950]	
			235					
520	1,144		520 [Radial: 460]	1,144 [Radial: 1,050]		450	1,074	
			-			100 (±50)		
			-			360° (min. control angle 0.001°)		
			38 to 3,800					
			2 auto ranges (2 range motor coil switching)					
			JIS A2-8					
			ø80					
			ø120					
V12			Multitasking V12 VDI (Axial) [Multitasking V12 radial]					
12			L and M: 12					
			25x25					
			ø40					
0.3			0.1					
			45 to 4,500 [Radial: 45 to 6,000]					
			Infinitely variable					
			X: 25, Z: 30			X: 25, Z: 30, Y: 10		
-	12		-	12		-	12	
			-			200		
-	MT No.5 (revolving center)		-	MT No.5 (revolving center)		-	MT No.5 (revolving center)	
-	400	980	-	400	980	-	400	980
			22/15 (20 min/cont)					
			7.0/3.3 (30 min/cont) [Radial: 5.5/3.7 (2 min/cont)]					
			2.8					
3.5	4.6		3.5	4.6		3.5	4.6	
			-			3.5		
-	2.9		-	2.9		-	2.9	
			0.55/0.75					
1,791		2,057	1,791		2,057	2,242		2,489
2,280x1,870	2,545x1,870	3,560x2,453	2,280x1,870	2,545x1,870	3,560x2,453	Under review	2,545x1,991	3,560x2,574
4,700	5,000	6,660	4,700	5,000	6,800	Under review	5,190	8,700
			OSP-P300LA					

[]: Optional

Tooling System

Unit: mm

GENOS L2000-e (L)

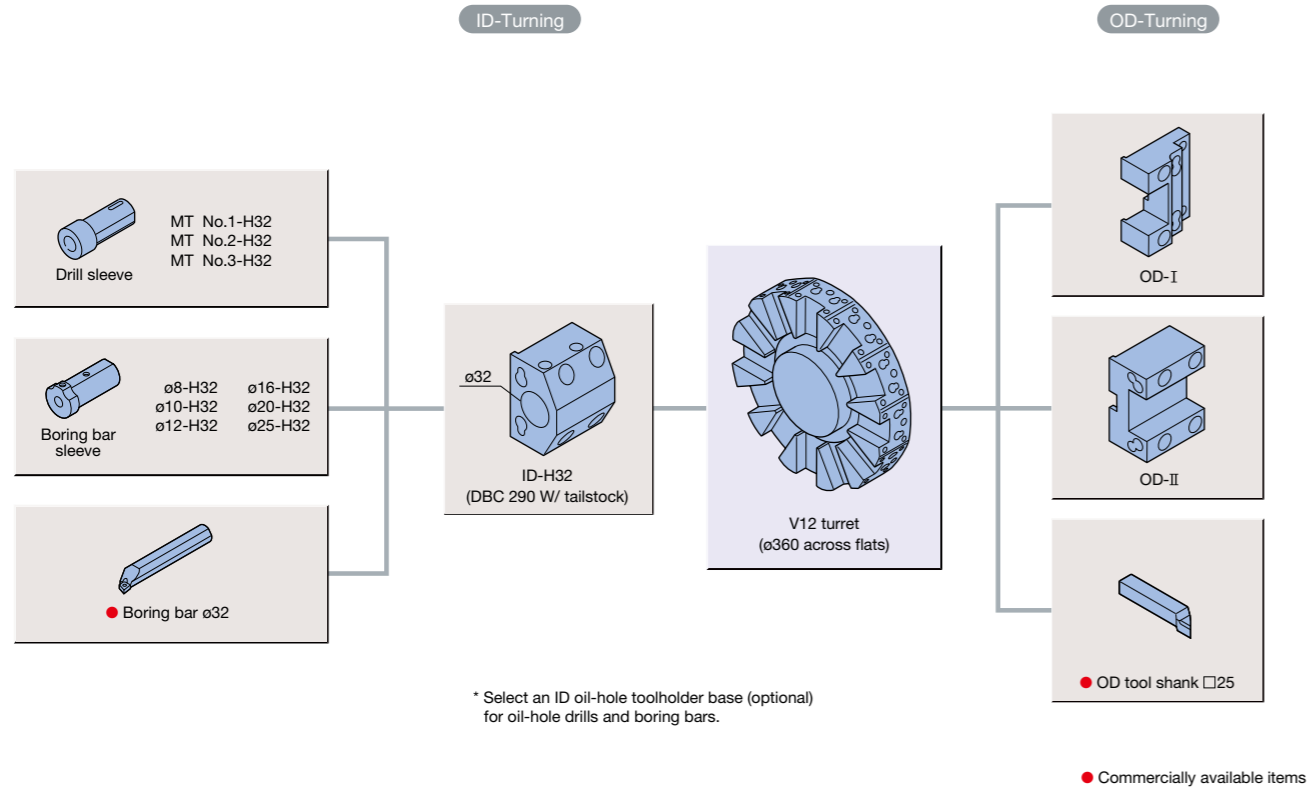

GENOS L2000-e (M) VDI multitasking turret

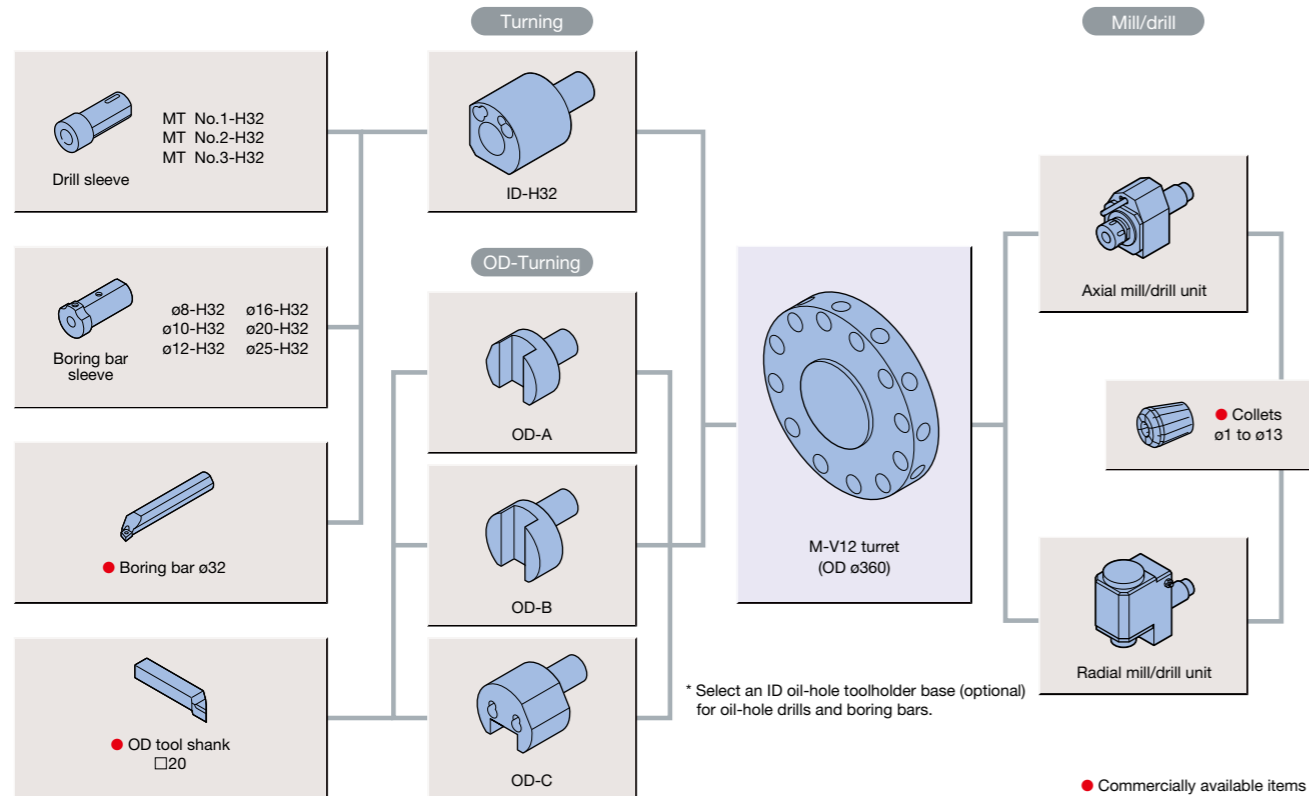

Unit: mm

GENOS L3000-e (L)

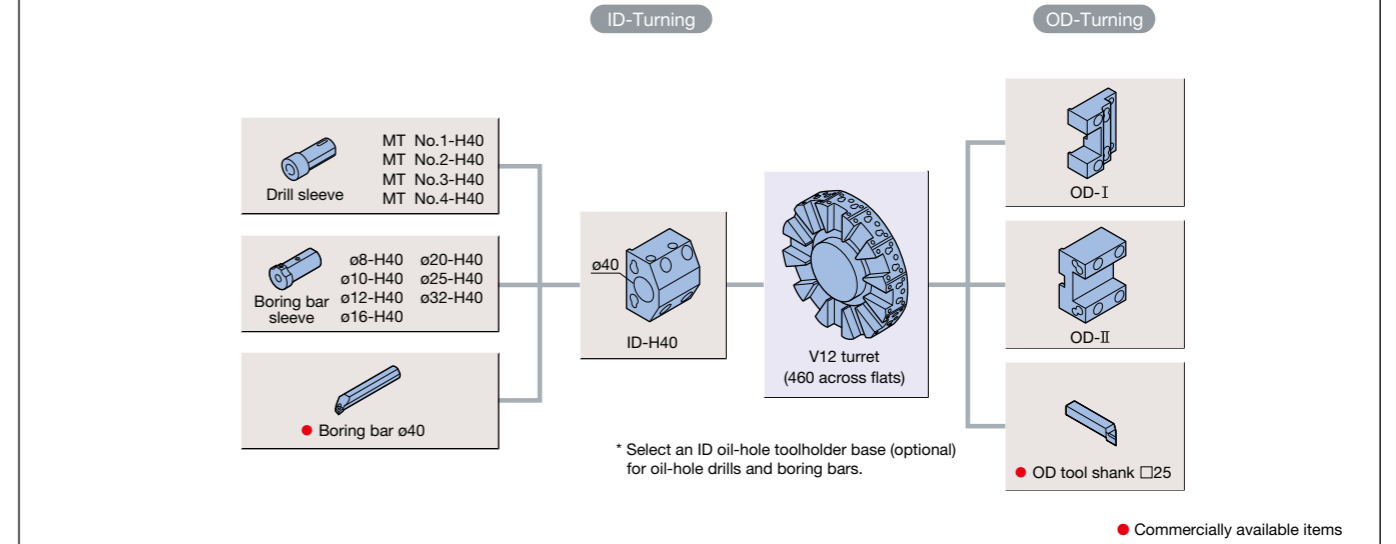

GENOS L3000-e (M) V12 VDI multitasking turret

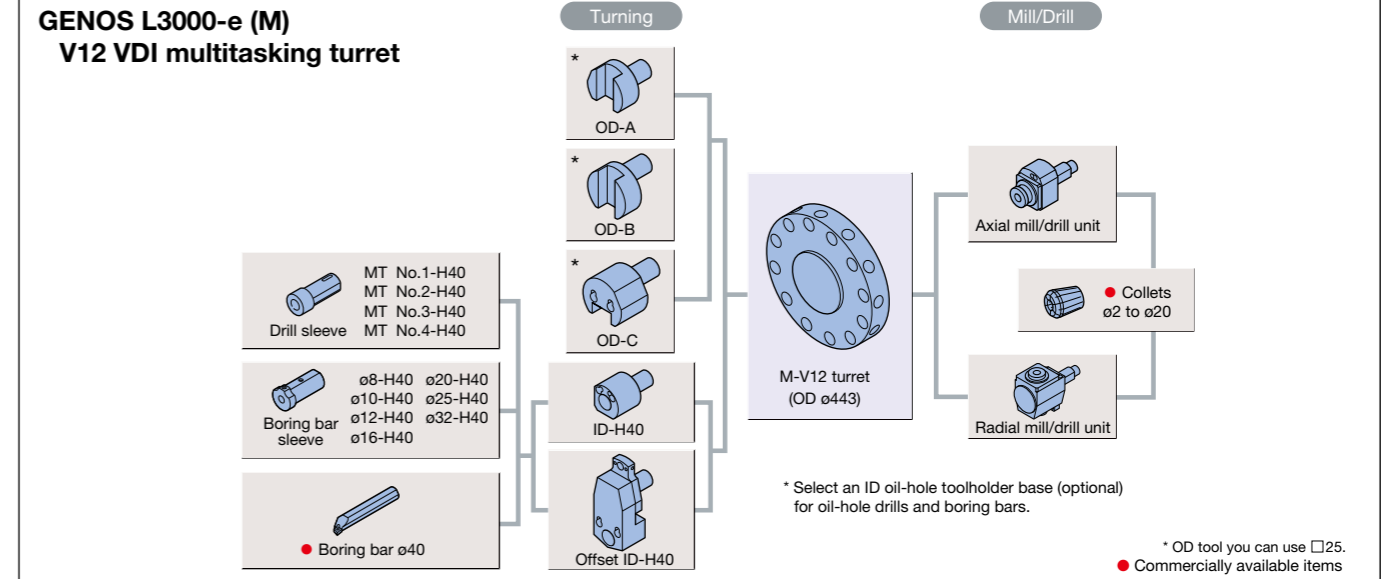

GENOS L3000-e (M) V12 radial multitasking turret

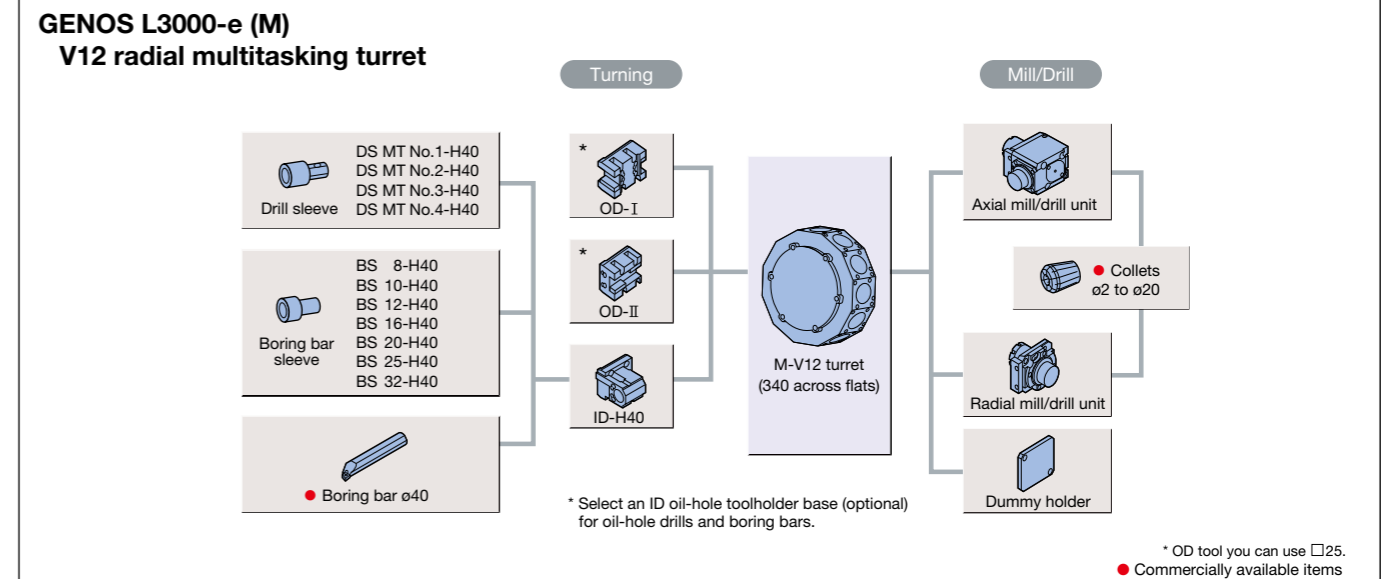

Working Ranges

Unit: mm

GENOS L2000-e (L) T V12 turret

OD-I

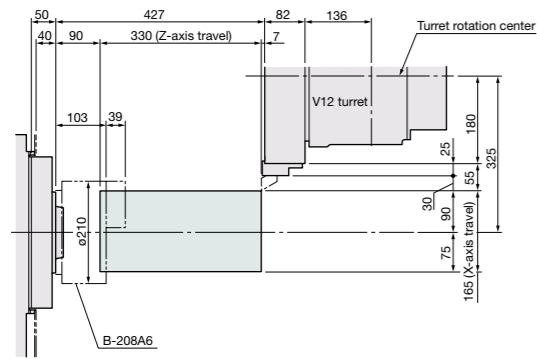

ID

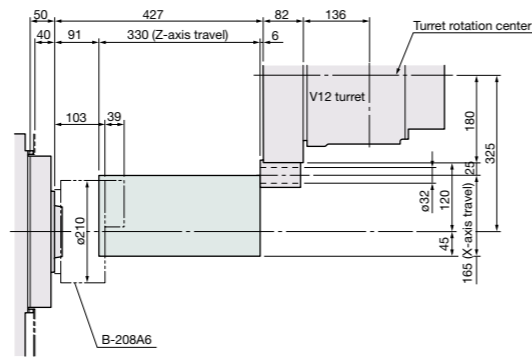

GENOS L2000-e (L) DBC 500 V12 turret W/ tailstock

OD-I

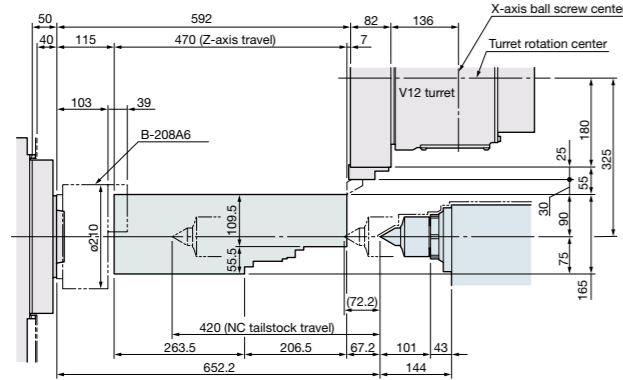

ID

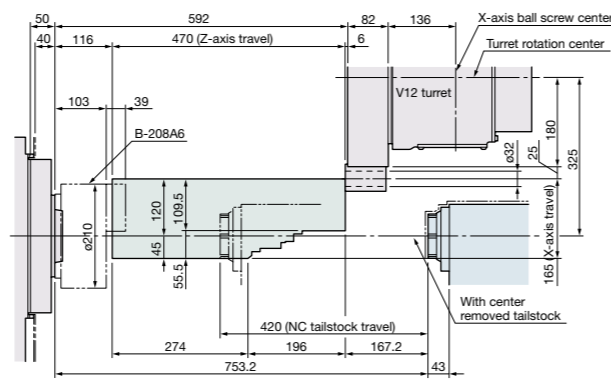

GENOS L2000-e (M) DBC 380 V12 VDI multitasking turret W/ tailstock

Axial drill/mill unit

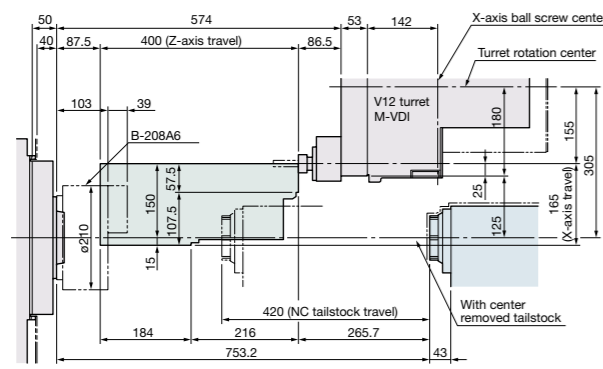

Radial drill/mill unit

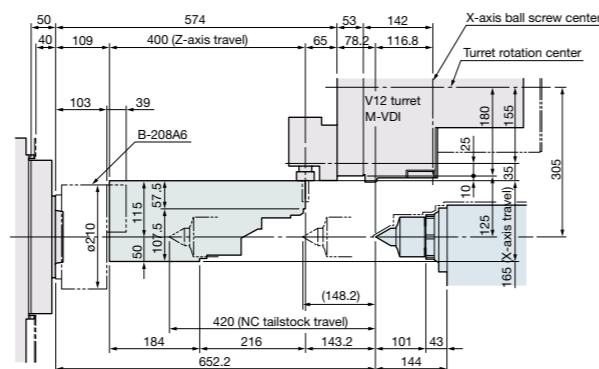

GENOS L2000-e (MY) DBC 380 V12 VDI turret W/ tailstock

Axial drill/mill unit

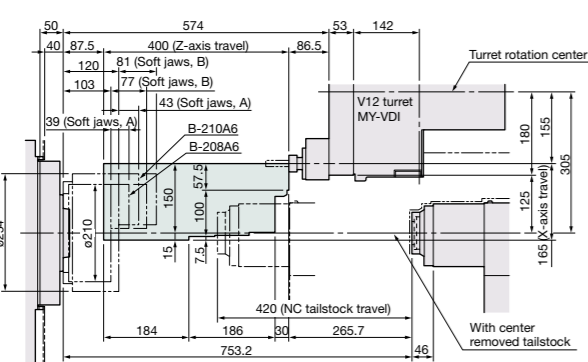

Radial drill/mill unit

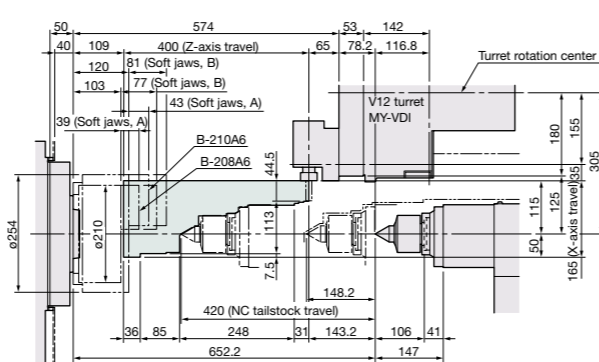

GENOS L3000-e (L) T V12 turret

OD-I

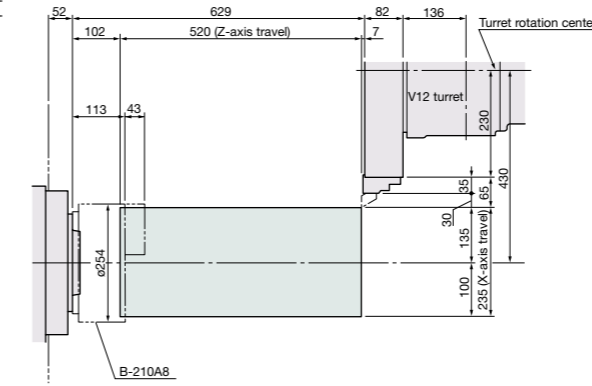

ID

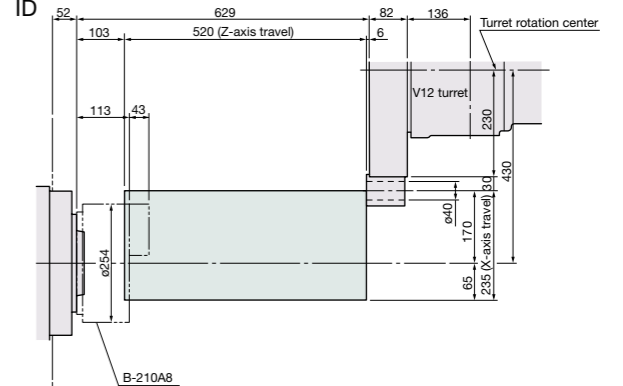

GENOS L3000-e (L) DBC 1100 V12 turret W/ tailstock

OD-I

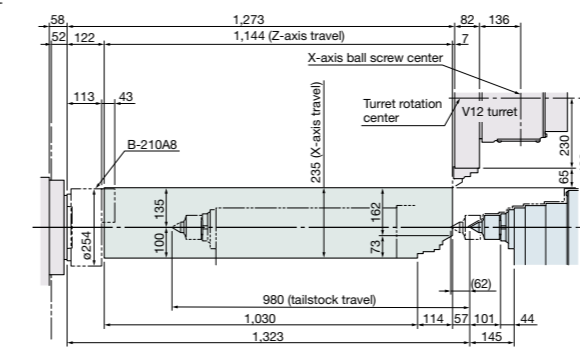

ID

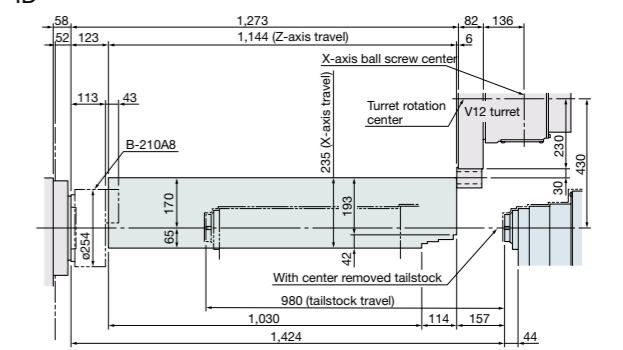

GENOS L3000-e (M) DBC 500 V12 VDI multitasking turret

Axial drill/mill unit

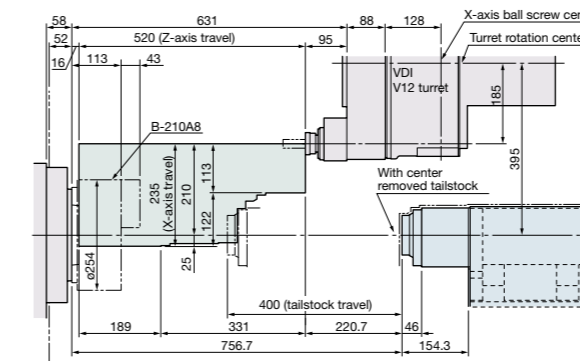

Radial drill/mill unit

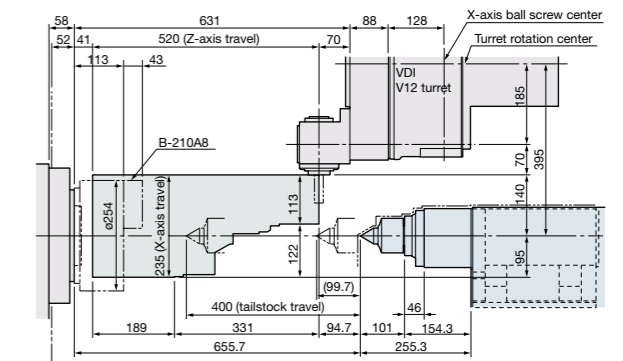

GENOS L3000-e (M) DBC 1000 V12 VDI multitasking turret

Axial drill/mill unit

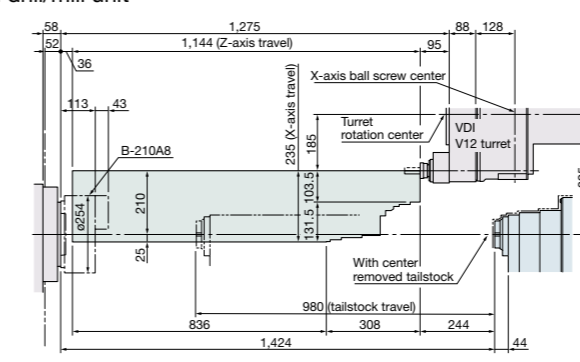

Radial drill/mill unit

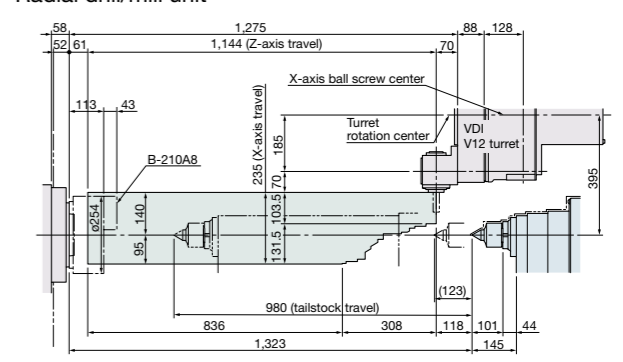

Dimensional Drawing

Unit: mm

GENOS L3000-e (L) DBC 500

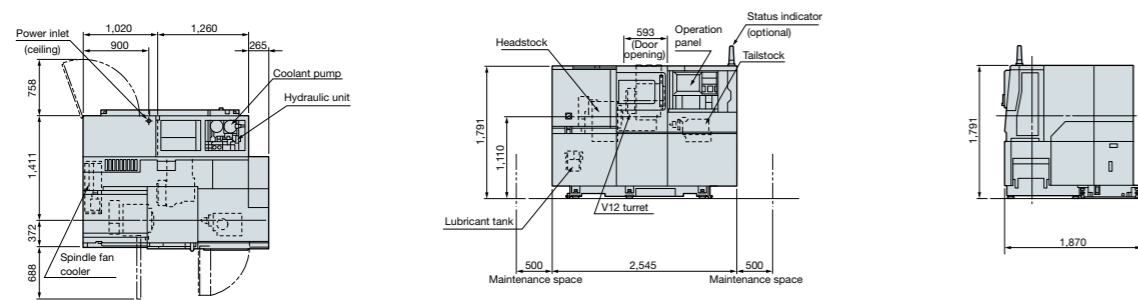

GENOS L3000-e (L) DBC 1100

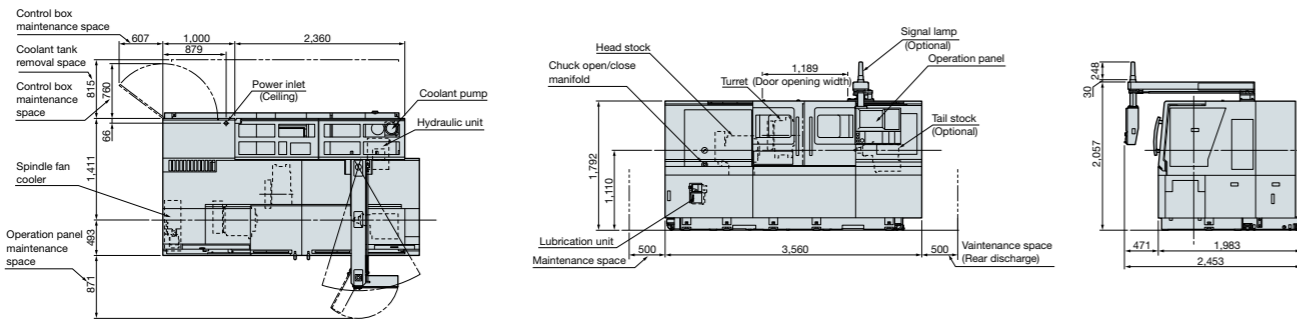

GENOS L3000-e (MY) DBC 400

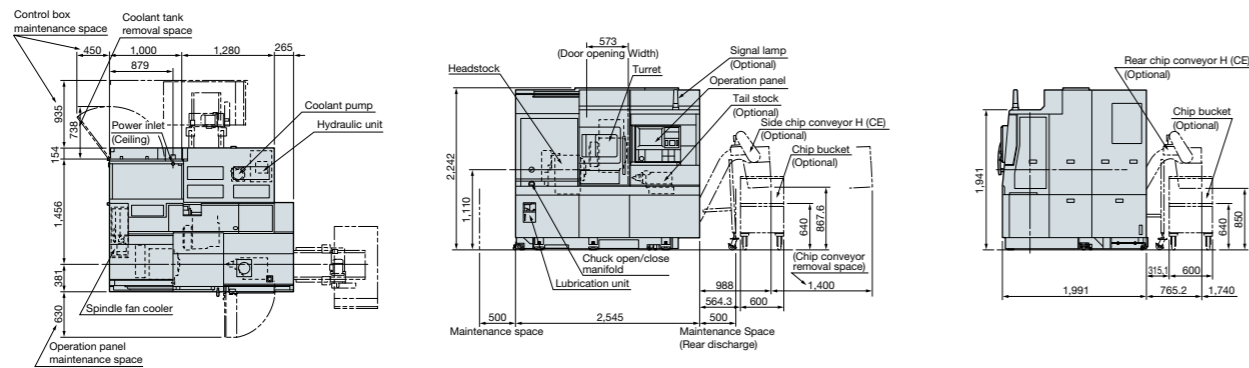

GENOS L3000-e (MY) DBC 1000

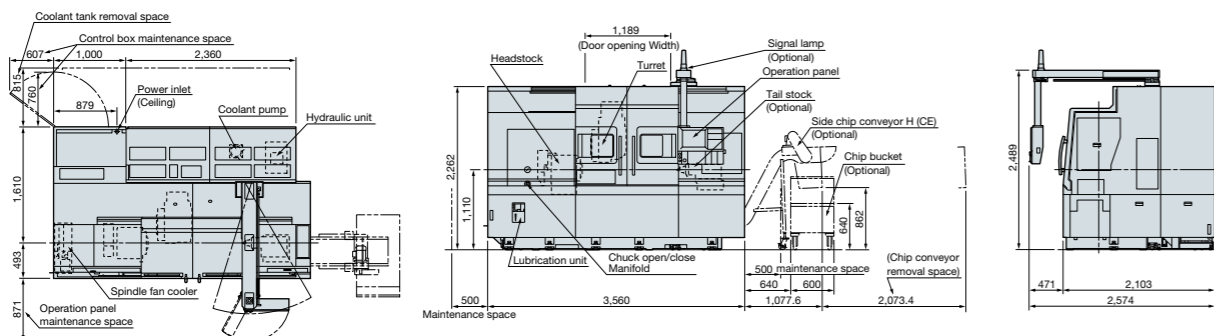

The Next-Generation Intelligent CNC

OSP suite OSP-P300LA-e

With revamped operation and responsiveness— ease of use for machine shops first!

Smart factories implement advanced digitization and networking (IoT) in "Monozukuri," (manufacturing) achieving enhanced productivity and added value. The OSP has evolved tremendously as CNC control suited to advanced intelligent technology. Okuma's new control uses the latest CPUs for a tremendous boost in operability, rendering performance, and processing speed. The OSP Suite also features a full range of useful apps that could only come from a machine-tool manufacturer, making smart manufacturing a reality.

Smooth, comfortable operation with the feeling of using a smart phone

Improved rendering performance and use of a multi-touch panel achieve intuitive graphical operation. Moving, enlarging, reducing, and rotating 3D models, as well as list views of tool data, programs, and other information can be accomplished through smooth, speedy operations with the same feel as using a smart phone. The screen display layout on the operation screen can also be changed to suit operator tastes, and customized for needs from beginning to veteran operator.



Features you wanted – loaded with new OSP suite apps!

We made these real through the addition of Okuma's machining expertise based on requests we heard from customers in the machine shop. These are filled with intelligence that enhances the "strength in the field" that CNC control can accomplish because it's created by a machine-tool manufacturer.



Increased productivity through visualization of motor power reserve

Spindle Output Monitor

The specified spindle output (red line: short time rating, green line: continuous rating) and the spindle output in current cutting (blue circle) are simultaneously displayed on the screen, for real-time view of power reserve during cutting. This allows speeding up cutting by increasing the spindle speed or feed rate while monitoring the graph to ensure that the blue circle does not cross the lines.



Easy programing without keying in code

Scheduled Program Editor



Monitoring utilization status even when away from the machine

E-mail Notification

OSP-P300LA-e

Okuma Sampling Path Control

Standard Specifications

Name	Description
■ Features	
Axis control	X, Z simultaneous 2-axis running, X, Z, C simultaneous 3-axis multi-processing
Position feedback	Full range absolute position (zero point return not required)
Tape format	N4.G3, X+53, Z+53, I+53, K+53, F+53, S4, T6, M3
RS-232C interface	RS-232C interface, 1 channel
Programming	Auto ISO/EIA code recognition, absolute, incremental or both
Min command units	X-axis: 1m(dia) Z-axis: 1m C-axis: 0.001°
Max command units	8-digit decimal, ±99999.999mm
Programmable units	Freely selectable: 1μm, 10μm, 1mm
Decimal point data	1μm, 10μm, 1mm increments
Feedrates feed	Feedrates are listed in the machine specs; override: 0~200%, dwell: 0.01~99999.99 sec.
Tooling	Tool selection: 8/12 sets, tool offset(compensation): 32 sets, max compensation value: 99999.999 mm Auto tool compensation: calculated from manually input wear and tear measurement values
Spindle VAC motor operation	Direct spindle speed commands (S4), fixed cutting speed Spindle speed override (50~200%), optimum turning speed designation
M-spindle motor operation (multi-machining)	Direct motor speed input
Display	15" Color display panel, multi-touch panel.
Manual operation	Spindle (inching, CW, CCW), tool rotation, pulse handle, X/Z-axis manual feed
Multitasking	Program writing, editing during work
Self-diagnostics	Automatic diagnostics and display of program, operation, machine and NC system problems
Door interlock	Safety function to interlock machine movement when the door is opened or closed
NC torque limiter	Instant detection of machine collision to reduce machine damage
Hi-G control	Calculates of the speed control and torque properties of a motor for high-speed, high-stability positioning
Thermal deformation prevention	Extremely accurate deformation control
Other	Buffer resister, zero offset, tool interference, software limit, chuck barrier, turret barrier, droop control, single block machine lock, block delete, optional stop, dry-run, stroke end-limit cancel, etc.

■ Operation	
OSP-Win 7	Featuring easy-to-manipulate screen windows, Pop-up function displays, Quick closing windows.
Sequence number search	Cursor advances to a specified sequence number in the selected program
Sequence restart	Restart from an interrupted sequence
Manual interrupt/auto return	Manual operation during automatic operation; return to interrupt point
Threading slide hold	Slide hold during threading (optional for G34/G35 non-fixed cycles)
Programming	Two programs can be edited simultaneously on one screen.
Memory operation*	Tapeless operation: Program storage capacity: 2GB, Operation backup capacity: 2MB
Useful help	Alarm help, G/M-code help, variable help, operation help, diagram display
PLC monitor	Display of PLC ladder drawings and PLC data

■ Output Management Function	
Display	Finished work list, operation results and alarm records
External output	Output above items to a USB port.

■ Programming Function	
Nose R compensation	Auto compensation for nose R dimension errors including arbitrary shapes and arcs
Arc radius designation	Circular interpolation by ordering the radius L and end points X and Z
Arbitrary angle chamfering	Simple programming of arbitrary angle chamfers (C, R)
Taper angle designation	Taper interpolation by designating either the X or Z-axis and the starting point angle
mm/min (ipm) programming	Both mm/rev and mm/min feedrate units are possible
Program schedule	Non-stop operation possible by setting the sequence order of several work programs
Zero offsets via G-codes	Program zero point offsets are possible
Threading	Thread lead: 0.001~1000.000mm; possible to set the threading lead pitch Chamfering on/off, fix cycle threading, non-fixed threading cycle (the thread lead indicates the CNC limit value, the max thread lead differs per machine specification)
Custom fixed cycle	Threading cycle, grooving cycle, drilling cycle
Fixed drilling cycle (multi-machining)	Drill, deep-hole drilling, boring, tapping
User task 1	GOTO, IF statements, arithmetic, common variable, local variable, system operation variables
Program notes	Comments can be added to programs

Optional Specifications

Name	Description	Kit		
		TE	TD	TEX
■ Programing				
User task 2	Sub-programming, function operations, logic operations I/O variables can be used(each 8 points)	○	○	○
Automatic programming (LAP4)	Add roughing conditions to finish programs for roughing to finish work optimized cutting by matching the best cutting mode with the material shape	○	○	○
Inch/metric switching	Inch, metric switching possible Via parameters		○	○
Arc threading	Threading possible along arc traces			
Tool offset compensation	<input type="checkbox"/> 96 sets <input type="checkbox"/> 200 sets (Standard 32 sets)			
Tool wear compensation	<input type="checkbox"/> 96 sets <input type="checkbox"/> 200 sets (Standard 32 sets)			
Coordinate switching (multi-machining)	Programming possible by changing X, C-axes to X, Y-axis rectangular coordinate system	△	△	△
Work generation (multi-machining)	Programming X, C-axis lines as straight flat surfaces is easy	△	△	△
Advance One touch IGF-L	Quick and simple: even operations without any NC knowledge can input a few keystrokes and be programming in on time Realistic 3D simulated test cut			
Real 3-D simulation	Real time simulation of all machining modes		○	○

■ Monitoring				
Condition display	Automatic operation, work completion, alarm conditions displayed with a 3-color (A-type) signal tower	○	○	○
NC operation monitor	Display of cutting, operation, spindle speed, etc., on the LED; workpiece count-up	○	○	○
NC work counter	Counts M30 occurrences (displayed on the LED): alarm-stop at count-up	○	○	○
Tool life management	Automatically calculates workpieces and cutting time, rotates a spare tool in when the set value for the tool life has been reached		○	○
Load monitor	Load conditions are monitored and X, Z-axis and the spindle stop with an alarm			○
Cycle time over check	An alarm occurs after the completion of a set cycle	○	○	○
DNC-T1	Ethernet part program transfers	○	○	○
DNC-T*	Personal computer DNC: Work program transfer, etc.			
Machining Navi L-g	Cutting condition search for turning			
Machining Navi T-g (Threading)	Cutting condition search in threading			

■ Gauging				
Auto work gauging/compensation	<input type="checkbox"/> Integral <input type="checkbox"/> External			
Touch setter tool tip	Automatic			

■ Automated Unattended Operation				
Chuck pressure switching	High/low switching via M-codes			
Tailstock quill pressure switching	High/low tailstock quill thrust switching with M-codes			
Auto door open/close	Auto door open/close via M-codes (w/ interlock ON/OFF switch)			
Air cleaner	An air blower is applied to the chuck area and the tailstock center via M-codes			
Extra M-codes	<input type="checkbox"/> 2 sets <input type="checkbox"/> 4 sets			
Auto power shut-off	Power supply is shut off automatically according to M30 and alarm conditions			
Cycle time reduction	Possible to ignore a various of answers with M-codes	○	○	○
Other*	<input type="checkbox"/> Chuck open/close during spindle rotation <input type="checkbox"/> Auto tailstock quill thrust during spindle rotation <input type="checkbox"/> Bar feeder interface <input type="checkbox"/> Loader interface <input type="checkbox"/> OSP-VPS (Virus Protection System)			

* Need to discuss with sales engineer △ Multi-machining Corresponding ○ Kit Corresponding

When using Okuma products, always read the safety precautions mentioned in the instruction manual and attached to the product.

● The specifications, illustrations, and descriptions in this brochure vary in different markets and are subject to change without notice.
Pub.No.GENOS-L2000-L3000-e-0EG-E-(2a)-200 (Oct 2018)

GENOS

The origin of gene, from Greek *genos*
meaning race, offspring, origin
(pronounced “γένος” as in “generous”)

Global
Efficient
No.1
Standard

When using Okuma products, always read the safety precautions mentioned in the instruction manual and attached to the product.

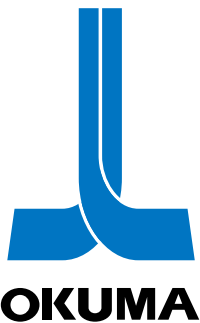

OKUMA Europe GmbH
Europark Fichtenhain A20
47807 Krefeld
Tel.: +49 (0)2151-374-0
Fax: +49 (0)2151-374100