

# ***LB4000EX II*** ***SPACE TURN***

1-Saddle CNC Lathe



# Transcending the Legendary LB

Okuma's best and long-selling LB Series, the spearhead of a wide range of CNC lathes, now provides new functionality for today's requirements, breakthrough possibilities for the next generation, and more reliability to satisfy greater customer expectations.

We are on a mission to "continuously enhance the LB to go beyond itself," and achieve **productivity improvements** linked to new strategic value chains.

## The SPACE TURN LB EX II Series.

Offering improved machining quality, speed, power and torque, process-intensive applications, automation . . .

All of the above—driven by the never-ending story of craftsmanship from Okuma.



# LB4000 EX II

## SPACE TURN

Photo includes optional specifications.  
Standard window size differs by market region.

## The machine against which all others will be measured

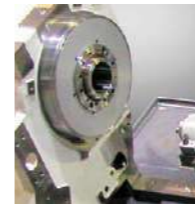

### Highest Quality

- Application of Thermo-Friendly Concept
- Slanted-box bed construction



### Super Fast and Rigid

- Equipped with new high-power, high-torque motor
- Combination of larger and faster spindle
- Large through-hole diameter, large working range
- Top rotation speed, horsepower, and torque in its class



### Extreme Versatility

- Abundant series variation
- NC tailstock standard equipment



### Easy Operation

**OSP suite** *OSP-P300LA*  
The Next-Generation Intelligent CNC

# Highest Quality

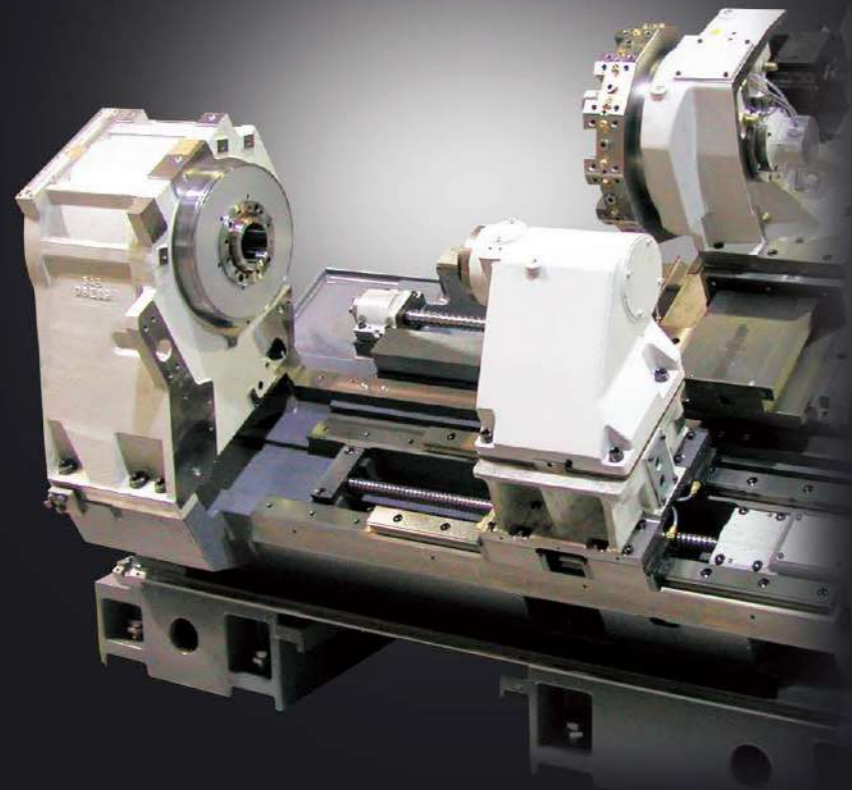

## Machining dimensional change over time: $\varnothing 7 \mu\text{m}$

Actual data [LB4000 EX II turning] (MY) (ambient temperature: 8°C change)

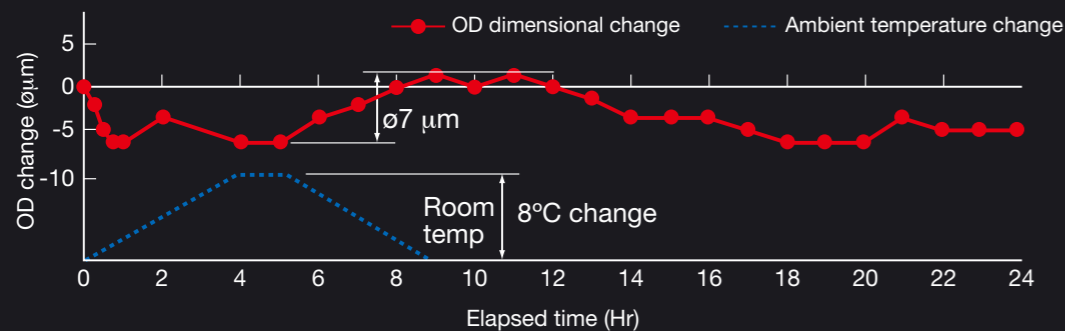

# High accuracy specifications overall assure machining with high dimensional stability

## Thermo-Friendly Concept for unparalleled dimensional stability

Okuma's Thermo-Friendly Concept is used on all the LB EX machines for extraordinary machining accuracy, using our unique machine design and thermal deformation control technology. Outstanding dimensional stability in long-time continuous operation, multitasking, and even Y-axis machining without troublesome compensation or warming up.

## Slanted-box bed configuration with superior construction and rigidity

The next evolution of the slanted-box bed construction that has been highly praised as a "rugged, Okuma-like construction" in the SPACE TURN series. The primary units of headstock and turret on a box bed is optimally placed for outstanding dimensional stability and high rigidity. Exhibits stable machining accuracy even in heavy cutting.

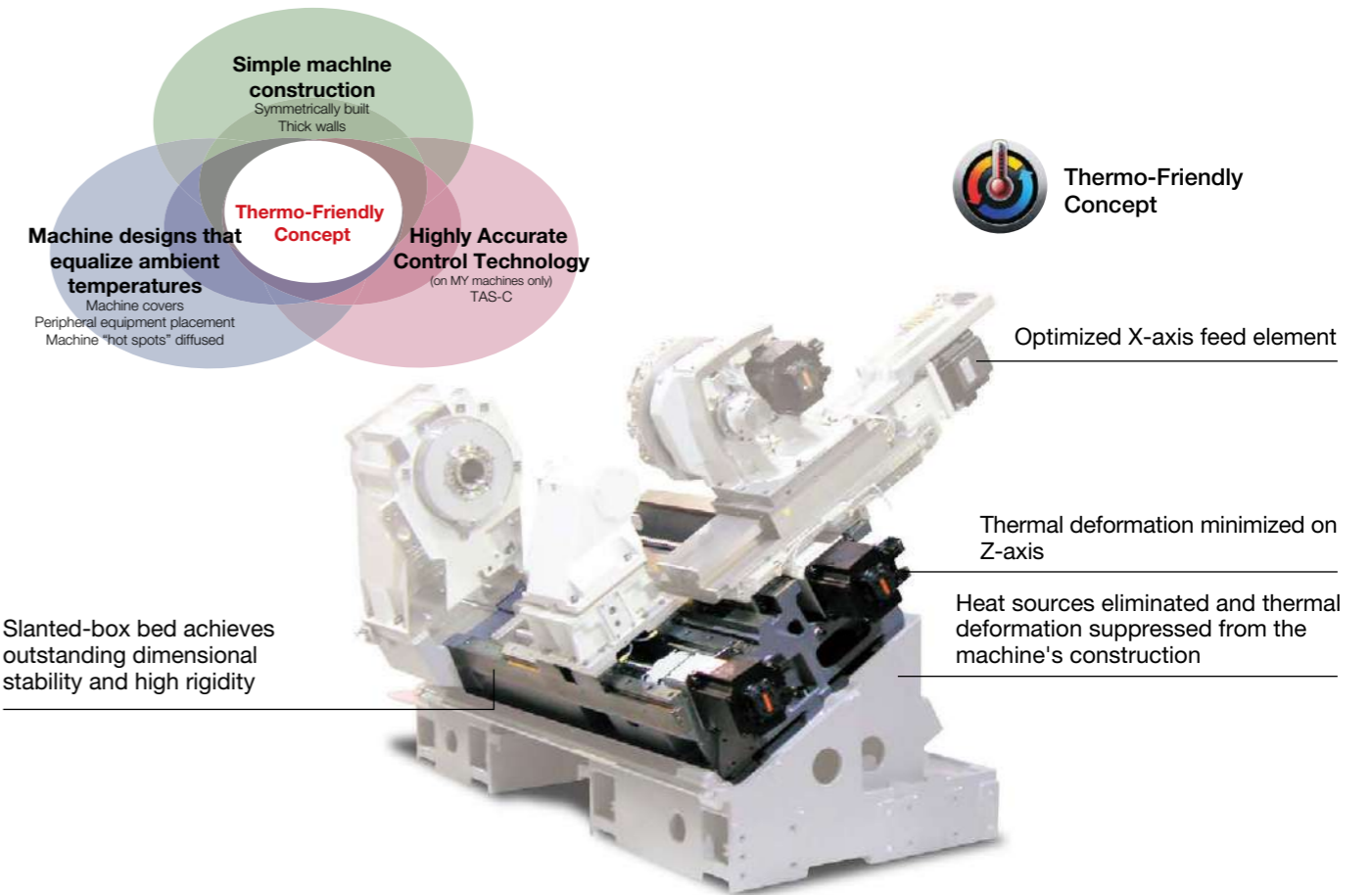

## Roundness [Actual data\*]

- Standard spindle  
0.4 μm / 2,000 min<sup>-1</sup>

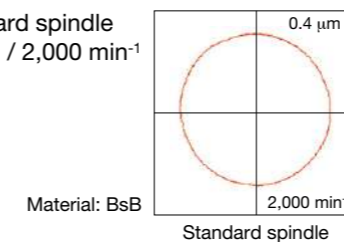

## Tool nose uniformity (for better surface roughness) [Actual data\*]

- Standard spindle: 0.3 μm / 2,000 min<sup>-1</sup>

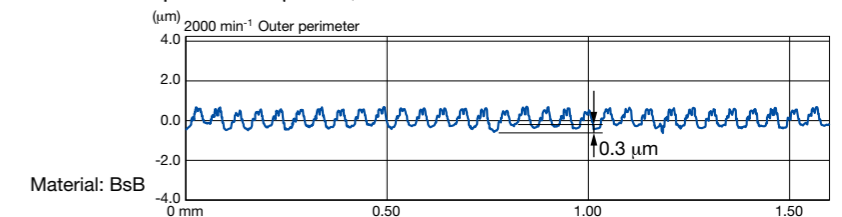

\* The "actual data" referred to above for this brochure represent examples, and may not be obtained due to differences in specifications, tooling, cutting and other conditions.

# Super Fast and Rigid

## Huge reduction in machining time with an original high power motor and faster machine movements

### Powerful motor on the spindle gives turning capacity of 6.3 mm<sup>2</sup>

Spindle with a larger bearing internal diameter of  $\phi 140$  mm can accommodate larger workpieces, and a turning capacity of 6.3 mm<sup>2</sup> is achieved with a high-speed, wide-area full power motor. Stable, high quality machining, from heavy to high speed cutting.

• Spindle size	Bearing ID $\phi 140$ (bore $\phi 91$ )
• Spindle speed	4,200 min <sup>-1</sup>
• Output	30 kW (40 hp)
• Torque	700 N-m (515 ft-lbf)

### Reduced operation time achieved with higher speed machine movements

• Rapid traverse	X: 25 m/min (984 ipm) Z: 30 m/min (1,181 ipm)
• Spindle start/stop	4.4 sec (4,200 min <sup>-1</sup> )
• Turret rotate	0.2 sec/index
• NC tailstock rapids	12 m/min (472 ipm)

### Turning 6.3 mm<sup>2</sup> (Workpiece: S45C)

[Actual data\*]

Cylindrical, heavy-duty cutting	6.3 mm <sup>2</sup> (0.01 in <sup>2</sup> )
	Cutting speed V: 150 m/min (492 fpm)
	Cutting depth t: 10 mm (0.39 in) Feedrate f: 0.63 mm/rev (0.02 ipr)
Drilling	$\phi 63$ ( $\phi 2.48$ ) carbide insert drill
	Cutting speed V: 179 m/min (587 fpm)
	Feedrate f: 0.25 mm/rev (0.01 ipr)

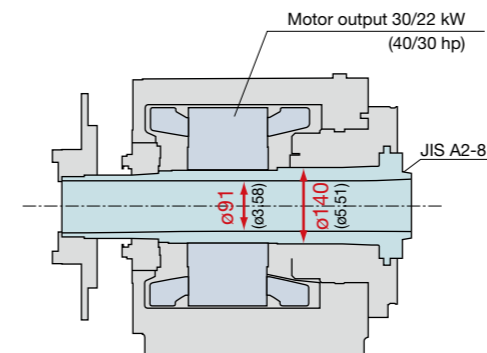

Integral motor/spindle—Okuma's own powerful motor—retains full power over a wide area. There are no gears or belts that can cause vibration or bending, for stable machining without chatter.

\* The "actual data" referred to above for this brochure represent examples, and may not be obtained due to differences in specifications, tooling, cutting and other conditions.

### Improved productivity: 20% shorter cycle time\*



\* Previous machine comparison

### Motor/spindle variations

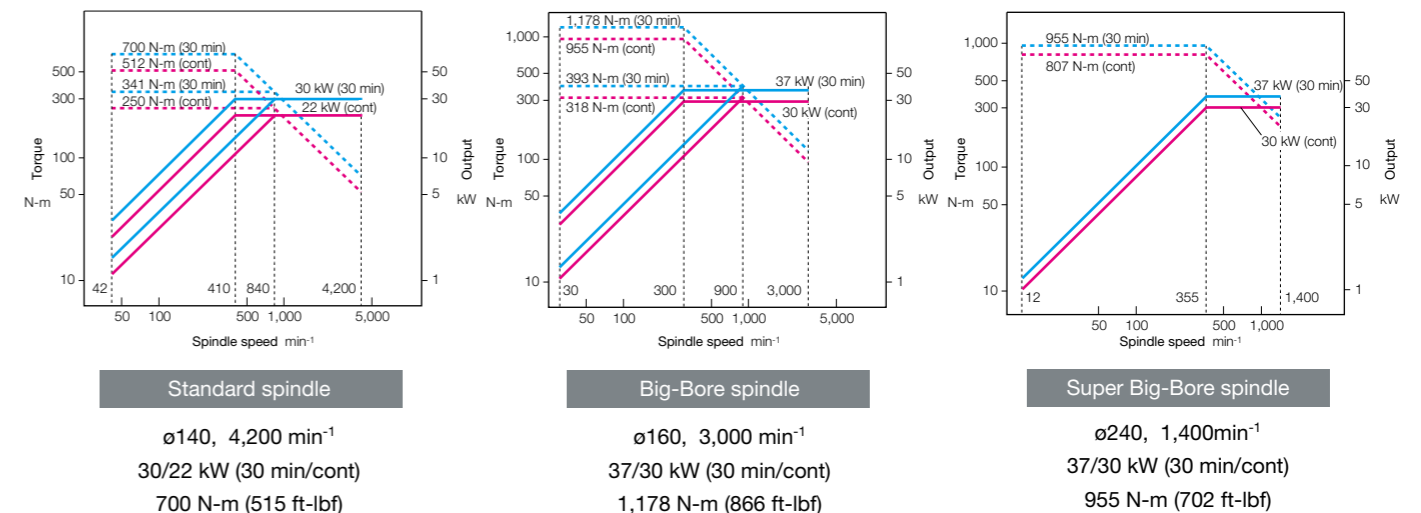

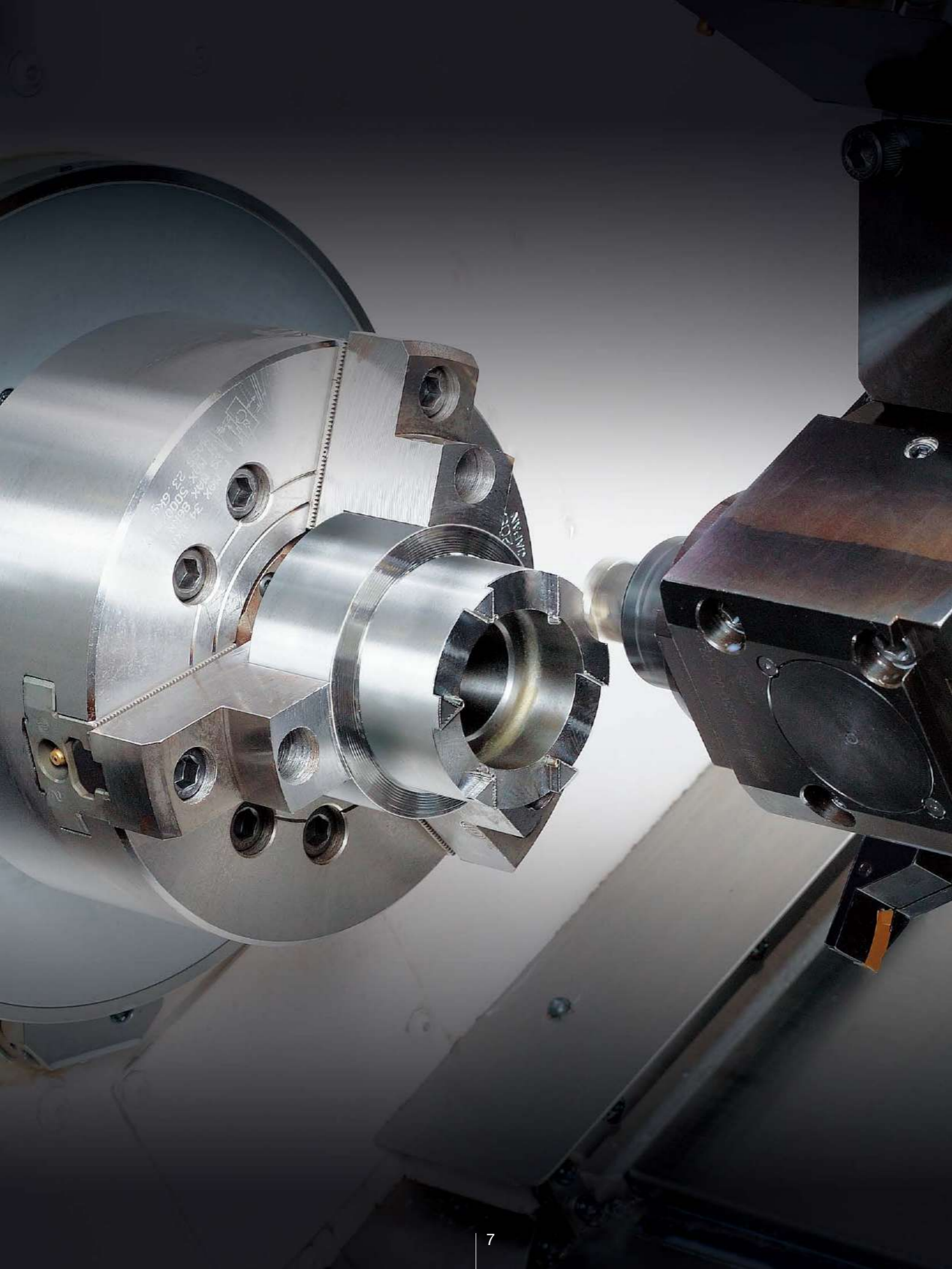

# Greater efficiency with highest milling performance in its class and fast tool change times

## Compact new PREX motor gives milling performance of 200 cm<sup>3</sup>/min

Compact, high-power, high-torque PREX motor also used for milling spindle of the multitasking V12 radial turret. This combined with a powerful, highly rigid bolt clamp system greatly increases multitasking speed.

• M spindle	6,000 min <sup>-1</sup>
• Output	7.5 kW (10 hp)
• Torque	58.1 N-m (42.7 ft-lbf)

## Reduced operation time achieved with higher speed machine movements

• Turret rotate	0.2 sec/ index
• M-spindle start/stop	0.4 sec (6,000 min <sup>-1</sup> )
• M-M switch	1.5 sec

## Milling capacity 200 cm<sup>3</sup>/min (Workpiece: S45C)

[Actual data\*]

**End milling** Chip volume 200 cm<sup>3</sup>/min (12.2 in<sup>3</sup>/min)  
 ø20 7-flute carbide end mill  
 Cutting speed V: 200 m/min (656.2 fpm)  
 Cutting depth t : 20 x 2.5 mm (0.79 x 0.09 in)  
 Feedrate f : 1.26 mm/rev (0.05 ipr)

**Face mill** Chip volume 177 cm<sup>3</sup>/min (11 in<sup>3</sup>/min)  
 ø80 face mill 8-blade  
 Cutting speed V: 312 m/min (1,024 fpm)  
 Cutting depth t : 1.6 x 56 mm (0.06 x 2.2 in)  
 Feedrate f : 1.6 mm/rev (0.06 ipr)

**Drilling** ø28 carbide insert drill  
 Cutting speed V: 90 m/min (295.3 fpm)  
 Feedrate f : 0.2 mm/rev (0.01 ipr)

**Tapping** M24 P3  
 (Synchronized tapping)

\* The "actual data" referred to above for this brochure represent examples, and may not be obtained due to differences in specifications, tooling, cutting and other conditions.



## Milling tool spindle

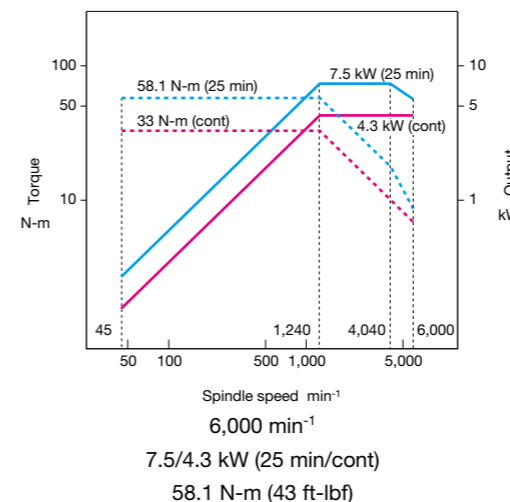

## Wide working range

### Max machining dia: ø480 mm (M turret: ø340 mm)

- Standard spindle: JIS A2-8 10-in chuck, 12-in chuck
- Big-Bore spindle: JIS A2-11 12-in chuck, 15-in chuck
- Super Big-Bore spindle: JIS A2-15 15-in chuck, 18-in chuck

### Distance between centers: 770/1,520/2,170 mm

### Spindle thru hole: Bigger

- Standard spindle: ø91 mm (ø3.59 in)
- Big-Bore spindle: ø112 mm (ø4.41 in)
- Super Big-Bore spindle: ø185 mm (ø7.28 in)

# Extreme Versatility



## Providing rich variation and optimum ease of use

### NC tailstock that shortens setup and automates center work is standard equipment

Up to 10 pairs of tailstock positions can be set, enabling continuous machining of workpieces with 10 different lengths without setup. In addition, thrust can be switched between high and low without resetting the workpiece. (Tailstock thrust high/low switch: Optional)  
High accuracy positioning is also possible with a high speed linear guide employing a ball screw guide.

• Tailstock thrust	1 to 7.5 kN (Opt: 1.5 to 10 kN)
• Rapid traverse	12 m/min (472 ipm)
• Approach	10 m/min (394 ipm)
• Retract	12 m/min (472 ipm)



Note: Please select a hydraulic quill for face driver machining applications.

### Complete multitasking with Y-axis functions One chuck machining even with irregularly shaped workpieces

A variety of milling operations can be accommodated with high-accuracy, wide-range Y-axis travel using a double slide system. Achieves complete multitasking with a single chucking (MY specifications).

• Travel	140 mm (+70 to -70) [5.51 in (+2.76 to -2.76)]
• Y-axis rapid traverse	12.5 m/min (492 ipm)

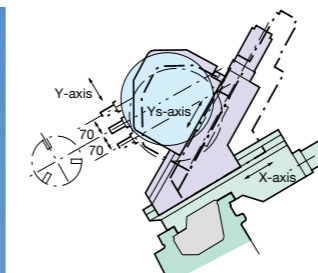

X•Y plane Radial Y-axis machining examples

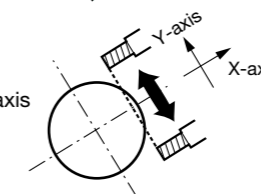

### Simple automation with parts catcher (Optional)

Automation can be achieved easily with a simple mechanism in which the bucket swings and discharges workpieces outside the machine.

### Front door with large window provides outstanding visibility (Optional) \*



\* Front door with large window shown here is a standard specification for the European market region.

## Complete control — always at your fingertips

- ◆ With “suite apps” to resolve shop floor problems and maximize productivity
- ◆ “Suite operation” provides stress-free, smartphone-like touch control
- ◆ Connect Plan allows you to have visual control of your plant
- ◆ Okuma smart factories evolving with AI coupled to reliable security applications



### CNC systems have evolved into a new form of cognitive computing

The OSP suite is no longer a CNC that only controls machining. Based on Okuma’s Intelligent Technology and a passion for “craftsmanship service,” each manufacturing process is optimized by digital links to shop floor work orders, setup information, cutting conditions, and operating status. Moreover, connections to plant equipment and maintenance information necessary for efficient factory operations, productivity of the entire manufacturing system improves considerably.

The OSP suite transforms machine tools into smart machines, working together as a team and evolving into a smart factory. And that will open the door to advances in manufacturing that have never before been possible.

### With revamped operation and responsiveness— ease of use for machine shops first!

Smart factories are using advanced digitization and networking (IIoT) in manufacturing to achieve enhanced productivity and added value. The OSP has evolved tremendously as a CNC suited to advanced intelligent technology. Okuma’s new control uses the latest CPUs for a tremendous boost in operability, rendering performance, and processing speed. The OSP suite also features a full range of useful apps that could only come from a machine tool manufacturer, making smart manufacturing a reality.

### Smooth, comfortable operation with the feeling of using a smart phone

Improved rendering performance and use of a multi-touch panel achieve intuitive graphical operation. Moving, enlarging, reducing, and rotating 3D models, as well as list views of tool data, programs, and other information can be accomplished through smooth, speedy operations with the same feel as using a smart phone. The screen display layout on the operation screen can also be changed to suit operator preferences and customized for the novice and/or veteran machinists.

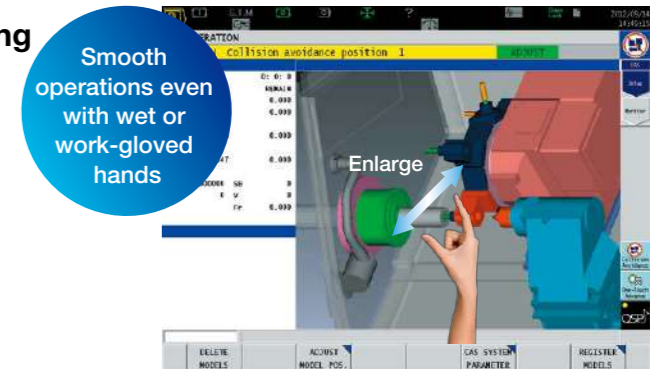

### “Just what we wanted.”— Refreshed OSP suite apps

This became possible through the addition of Okuma’s machining expertise based on requests we heard from real, machine-shop customers. The brain power packed into the CNC, built by a machine tool manufacturer, will “empower shop floor” management.



#### Spindle Output Monitor

Increased productivity through visualization of motor power reserve

The specified spindle output (red line: short time rating, green line: continuous rating) and the spindle output in current cutting (blue circle) are simultaneously displayed on the screen, for real-time view of power reserve during cutting. This allows speeding up cutting by increasing the spindle speed or feed rate while monitoring the graph to ensure that the blue circle does not cross the lines.



#### Scheduled Program Editor

Easy programming without keying in code



#### E-mail Notification

Monitoring utilization status even when away from the machine

### Connect Plan Get Connected, Get Started, and Get Innovative with Okuma “Monozukuri”

#### Connect, Visualize, Improve

Okuma’s Connect Plan is a system that provides analytics for improved utilization by connecting machine tools and visual control of factory operation results and machining records. Simply connect the OSP and a PC and install Connect Plan on the PC to see the machine operation status from the shop floor, from an office, from anywhere. The Connect Plan is an ideal solution for customers trying to raise their machine utilization.

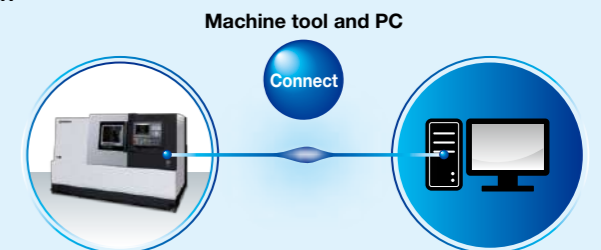

# Ensuring smooth machining preparations

## Interactive operations Advanced One-Touch IGF-L (Optional)

### Part program create

After simple cutting data inputs (interactively), the required machining processes are determined and a part program is created (automatically).

### Advanced run

To run the machine directly from the interactive part program screen. When a problem is detected it can be quickly corrected and checked, speeding up first part machining.

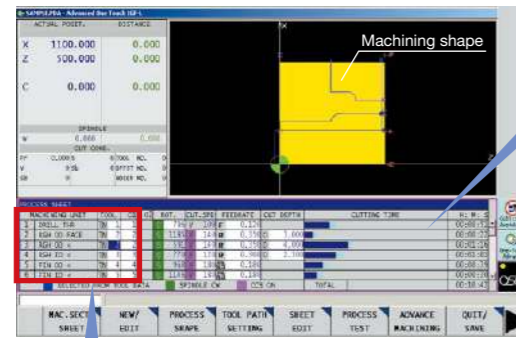

Directly change cutting conditions for each process with this process sheet

Tables make it easy to make mid-cycle or individual process starts

PROCESS SHEET	<CONTINL
MACHINING UNIT	TOOL
1	DRILL THR TN 1
2	RGH OD FACE TN 2
3	RGH OD < TN 2
4	RGH ID < TN 3
5	FIN OD < TN 4
6	FIN ID < TN 5

Continuous run

PROCESS SHEET	<CONTINL
MACHINING UNIT	TOOL
1	DRILL THR TN 1
2	RGH OD FACE TN 2
3	RGH OD < TN 2
4	RGH ID < TN 3
5	FIN OD < TN 4
6	FIN ID < TN 5

Mid-cycle start (finishing repeated)

PROCESS SHEET	<SINGLE
MACHINING UNIT	TOOL
1	DRILL THR TN 1
2	RGH OD FACE TN 2
3	RGH OD < TN 2
4	RGH ID < TN 3
5	FIN OD < TN 4
6	FIN ID < TN 5

Individual run (machining repeated with this tool only)



## Easy to operate

### Operation screen split into four displays

Simultaneous display includes setup work, current position needed in confirming movement in trial machining, NC program, and graphic simulation.



### Tool registration

Register data for all of your tools. Since the registered tool data is also used by Okuma auto programming (Advanced One-Touch IGF) and a collision check function (Collision Avoidance System), this screen will complete the entire registering process. When loading a tool in the machine, simply select it from among the registered tools. ATC manual operation does not require inputting the tool number. Just select the tool from the list and press the function key.



### Forming soft jaws

Templates like this make it easy to set required jaw shape, tool, and cutting conditions. Part programming not required to do this.



### Zero offsets

A simple function key operation is all it takes to shift a zero offset to either the left or right end of a workpiece. The required zero offset will be calculated automatically based on jaw and workpiece lengths. (when the tool offset is set with reference to the turret tool mounting surface)



# Okuma's Intelligent Technology reduces operator burden



## Machining Navi L-gII (guided, harmonic spindle speed control) (Optional)

Cutting condition search function for turning

Varying the spindle speed in accordance with the best amplitude and period makes it possible to suppress chatter during turning operations. Tool life can be extended and machining time reduced with use of the optimum cutting conditions, producing significant effects in drilling/boring bar, threading, and grooving applications.

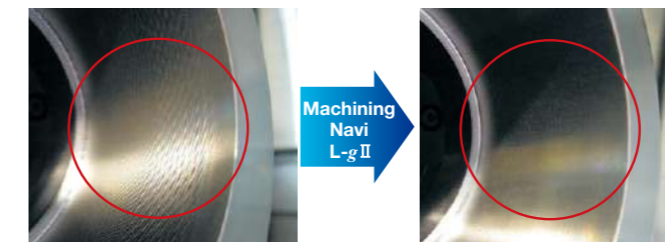
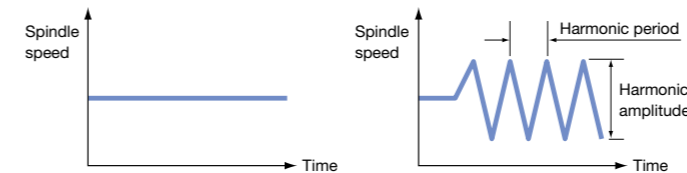

## Machining Navi T-g Threading (Optional)

Cutting condition search in threading

When chatter occurred during threading, it was common to lower the cutting conditions or use special tools that resist chatter. Okuma's Machining Navi T-g (Threading) breaks the vibration periodicity with a different spindle speed for each threading pass, and suppresses chatter growth. The machining capacity of your normally used tools can be maximized for stable machining.

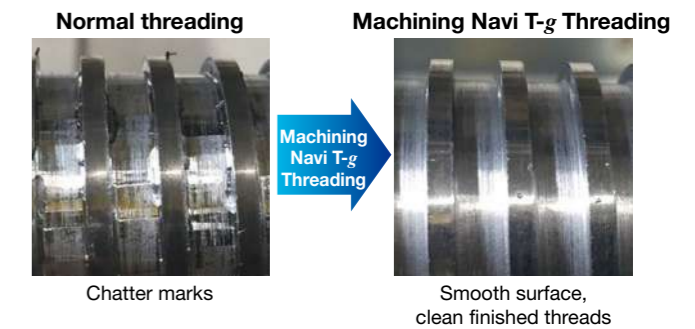
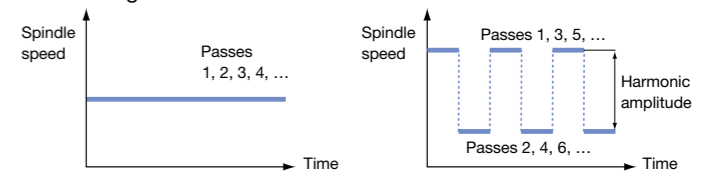

## ECO suite Next-Generation Energy-Saving System

A suite of energy saving applications for machine tools

### ECO Idling Stop

Operation only for the time required for each unit. Idling can be stopped for individual spindle, feed drives, and peripheral equipment. By reducing the idling time, power consumption can also be reduced.

● Example of equipment that can use Idling Stop

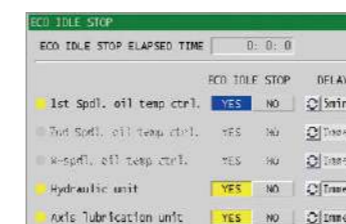

### ECO Power Monitor

On-the-spot check of energy savings. Power is shown individually for spindle, feed axes, and auxiliaries on the OSP operation screen. The energy-saving benefits from auxiliary equipment stopped with ECO Idling Stop can be confirmed on the spot.

● Example of Power Monitor check

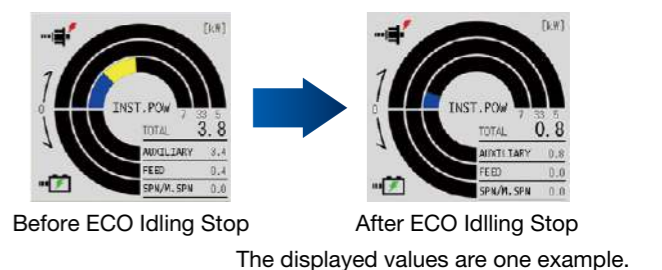

## Standard Specifications

Name	Model	LB4000 EX II (L)			
		T	C×750	C×1500	C×2000
Capacity	Swing over bed	mm (in) ø670 (ø26.38)			
	Swing over saddle	mm (in) ø480 (ø18.90)			
	Distance between centers	—	770 (30.31)	1,520 (59.84)	2,170 (85.43)
	Max turning dia	mm (in) ø480 (ø18.90)			
	Max work length	380 (14.96)	750 (29.53)	1,500 (59.06)	2,150 (84.65)
Travels	X axis	mm (in) 300 (11.81)			
	Z axis	840 (33.07)		1,590 (62.60)	
	Y axis	mm (in) —			
	C axis (minimum control angle)	deg —			
Spindle	Speed	min <sup>-1</sup> 42 to 4,200 [30 to 3,000] <12 to 1,400>			
	Speed ranges	2 auto ranges (2 range motor coil switching) <Infinitely variable>			
	Nose	JIS A2-8 [JIS A2-11] <JIS A2-15>			
	Bore dia / Front bearing dia	mm (in) ø91 [ø112] <ø185> [ø3.58 [ø4.41] <ø7.28>] / ø140 [ø160] <ø240> [ø5.51 [ø6.30] <ø9.45>]			
Turret	Type	V12 NC turret			
	No. of tools	L: 12			
	OD tool shank	mm (in) 25 × 25 (1 × 1)			
	ID tool shank dia	mm (in) ø40 (ø1-1/2)			
	Turret rotation	sec/index 0.2			
Milling tool	Spindle speed	min <sup>-1</sup> —			
	Speed range	—			
Feed rates	Rapid traverse	m/min (ipm) X: 25, Z: 30 (984, 1,181)			
	Tailstock rapids	—	12 (472)		
	Rapid traverse (C)	min <sup>-1</sup> —			
Tailstock	Tapered bore type	—	MT No. 5		
	Quill travel	—	780 (30.71)	1,530 (60.24)	2,180 (85.83)
Motors	Main spindle (30 min/cont)	kW (hp) 30/22 (40/30) [37/30 (50/40)] <37/30 (50/40)>			
	Milling tool spindle	kW (hp) —			
	Axis drive	kW (hp) X: 3.5 / Z: 4.6 (4.73/6.21)			
	Tailstock travel	—	2.9 (3.9)		
	Coolant pump (50/60 Hz)	SD*: 0.25/0.25 (0.33/0.33)		SD*: 0.25/0.25 (0.33/0.33)	
Machine size	Height	1,955 (76.97)		2,005 (78.94)	
	Floor space*1	mm × mm (in) 3,100 × 1,921 (122 × 76)		5,515 × 2,505 (217 × 99)	
	Mass (w/ CNC)*1	6,000 (13,200)	6,300 (13,860)	8,200 (18,040)	11,000 (24,200)
CNC	OSP-P300LA				

\* SD: Side discharge, RD: Rear discharge

Name	LB4000 EX II (M)			LB4000 EX II (MY)				
	T	C×750	C×1500	C×2000	T	C×750	C×1500	C×2000
Capacity	mm (in) ø670 (ø26.38)							
	mm (in) ø480 (ø18.90)							
	—	770 (30.31)	1,520 (59.84)	2,170 (85.43)	—	770 (30.31)	1,520 (59.84)	2,170 (85.43)
	mm (in) ø430 (ø16.93)							
	380 (14.96)	750 (29.53)	1,500 (59.06)	2,150 (84.65)	380 (14.96)	750 (29.53)	1,500 (59.06)	2,150 (84.65)
Travels	mm (in) 300 (11.81)							
	840 (33.07)		1,590 (62.60)		840 (33.07)		1,590 (62.60)	
	mm (in) —				140 (±70)			
	360 (0.001)							
Spindle	min <sup>-1</sup> 42 to 4,200 [30 to 3,000] <12 to 1,400>							
	2 auto ranges (2 range motor coil switching) <Infinitely variable>							
	JIS A2-8 [JIS A2-11] <JIS A2-15>							
	mm (in) ø91 [ø112] <ø185> [ø3.58 [ø4.41] <ø7.28>] / ø140 [ø160] <ø240> [ø5.51 [ø6.30] <ø9.45>]							
Turret	M-V12 NC turret (radial)							
	L / M: 12							
	mm (in) 25 × 25 (1 × 1)							
	mm (in) ø40 (ø1-1/2)							
	sec/index 0.2							
Milling tool	min <sup>-1</sup> 45 to 6,000							
	Infinately variable							
Feed rates	X: 25, Z: 30 (984, 1,181)			X: 25, Z: 30, Y: 12.5 (984, 1,181, 492)				
	—	12 (472)			—	12 (472)		
	200							
Tailstock	MT No. 5			MT No. 5				
	—	780 (30.71)	1,530 (60.24)	2,180 (85.83)	—	780 (30.71)	1,530 (60.24)	2,180 (85.83)
Motors	30/22 (40/30) [37/30 (50/40)] <37/30 (50/40)>							
	7.5/4.3 (10/5.7) (25 min/cont)							
	X: 3.5 / Z: 4.6 (4.73/6.21)			X: 3.5 / Z: 4.6 / Ys: 3.5 (4.73/6.21/4.73)				
	—	2.9 (3.9)			—	2.9 (3.9)		
	SD*: 0.25/0.25 (0.33/0.33)		SD*: 0.25/0.25 (0.33/0.33)		SD*: 0.25/0.25 (0.33/0.33)		SD*: 0.25/0.25 (0.33/0.33)	
Machine size	1,955 (76.97)		2,157 (84.92)		2,005 (78.94)		2,320 (91.34)	
	3,100 × 1,921 (122 × 76)		4,175 × 2,390 (164 × 94)		5,515 × 2,505 (217 × 99)		3,100 × 1,921 (122 × 76)	
	6,000 (13,200)	6,300 (13,860)	8,200 (18,040)	11,000 (24,200)	6,400 (14,080)	6,700 (14,740)	8,600 (18,920)	12,000 (26,400)
CNC	OSP-P300LA							

[ ] : Big-Bore spindle specs < > : Super Big-Bore spindle specs  
\*1: Standard spindle/side discharge specs, tank included

## Standard Specifications & Accessories

Model Specifications	LB4000 EX II					
	L		M		MY	
	T	C	T	C	T	C
Spindle	A2-8 42 to 4,200 min <sup>-1</sup> 30/22 kW (40/30 hp) (30 min/cont)					
Turret	NC indexing					
Milling tool spindle	V12 bolt clamp		M-V12 radial			
	—		45 to 6,000 min <sup>-1</sup> 7.5/4.3 kW (10/5.7 hp) (25 min/cont)			
Tailstock	—	NC travel Dead quill MT 5	—	NC travel Dead quill MT 5	—	NC travel Dead quill MT 5
Standard accessories	Coolant system (water soluble)					
	Work lamp (LED)					
	Full enclosure shielding					
	Jack screws, foundation washers					
	Hand tools					
Standard accessories	Door interlock (standard)					
	Lube monitor (A-1 + hydraulic pressure source detector)					
CNC	OSP-P300LA					
	NC operation panel, 15-in color TFT (touch panel)					
	Program storage; 4 GB					
	Operation buffer; 2 MB					

## Chucking Kit

	BB kit: *1	E kit: *2	D kit: *3
Chuck	Hollow 10 in BB210A8	Hollow 10 in B-210A8	Hollow 12 in B-212A8

## Chucking Kit / Tooling Kit

Model Specifications	LB4000 EX II										
	L			M			MY				
	Std Chucking Kit	Std Tooling Kit	Chucking Kit	Chucking Kit	Chucking Kit	Chucking Kit	Chucking Kit	Chucking Kit	Chucking Kit	Chucking Kit	
Chuck	Solid 10 in N-10A8		BB kit *1	E kit *2	D kit *3	BB kit *1	E kit *2	D kit *3	BB kit *1	E kit *2	D kit *3
Soft jaws, A			5			5			5		
Soft jaws, B			3			3			3		
Hard jaws			1			1			1		
OD-I		4	6			6			6		
OD-II		2	3			2			2		
ID-H40		6	6			4			4		
DS MT No. 1-H40			1								
DS MT No. 2-H40			1								
DS MT No. 3-H40		1	1			1			1		
DS MT No. 4-H40			1								
BS 10-H40			2			2			2		
BS 12-H40			2			2			2		
BS 16-H40			2			2			2		
BS 20-H40		2	2			2			2		
BS 25-H40		2	2			2			2		
BS 32-H40			2			2			2		
Axial mill/drill unit						2			2		
Radial mill/drill unit						2			2		
Dummy holder						3			3		
Revolving center MT No. 5*						1			1		

\* Not available for T model specifications

## Tooling System

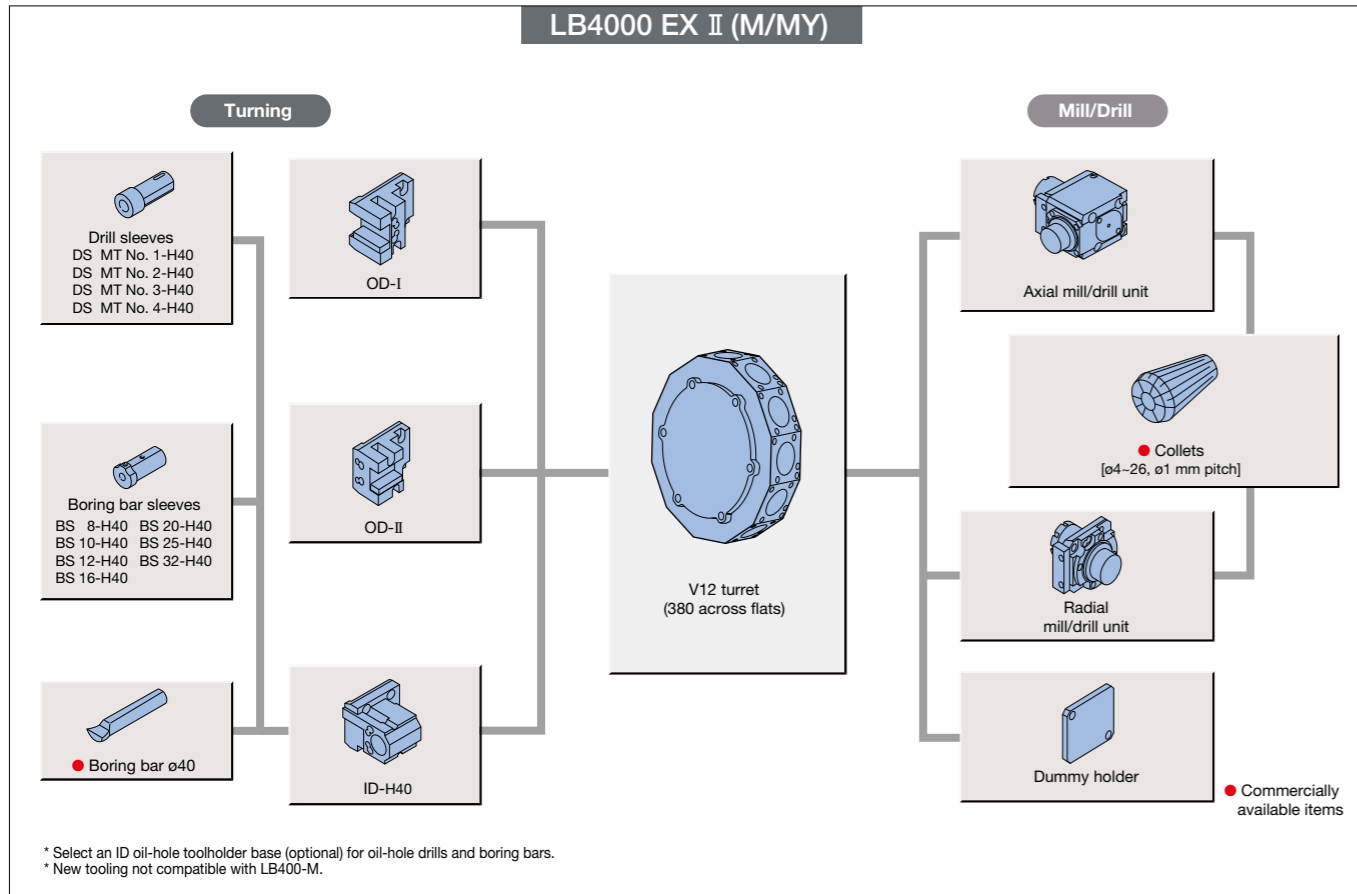
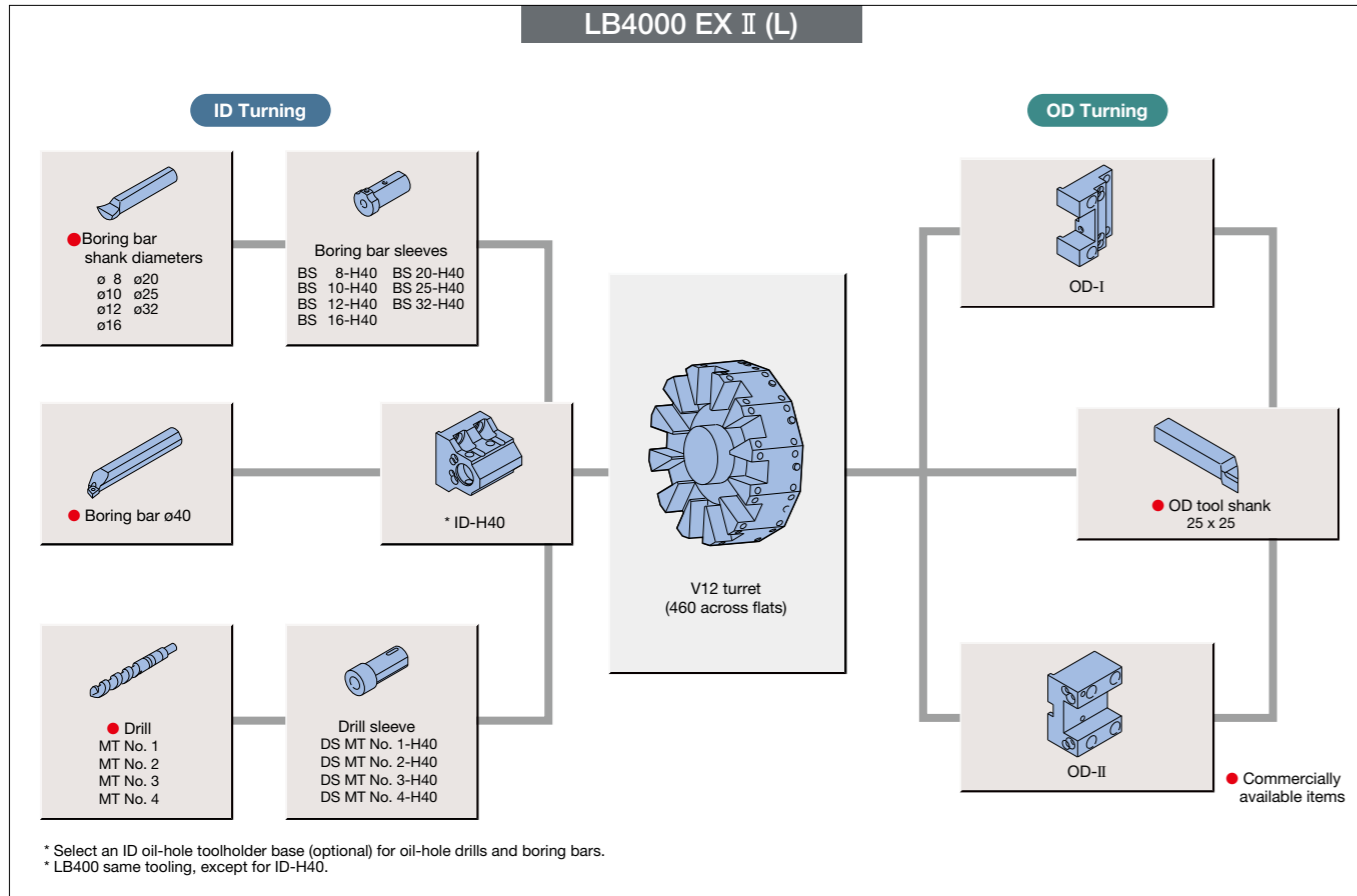

## Tool Interference Drawings

Unit: mm

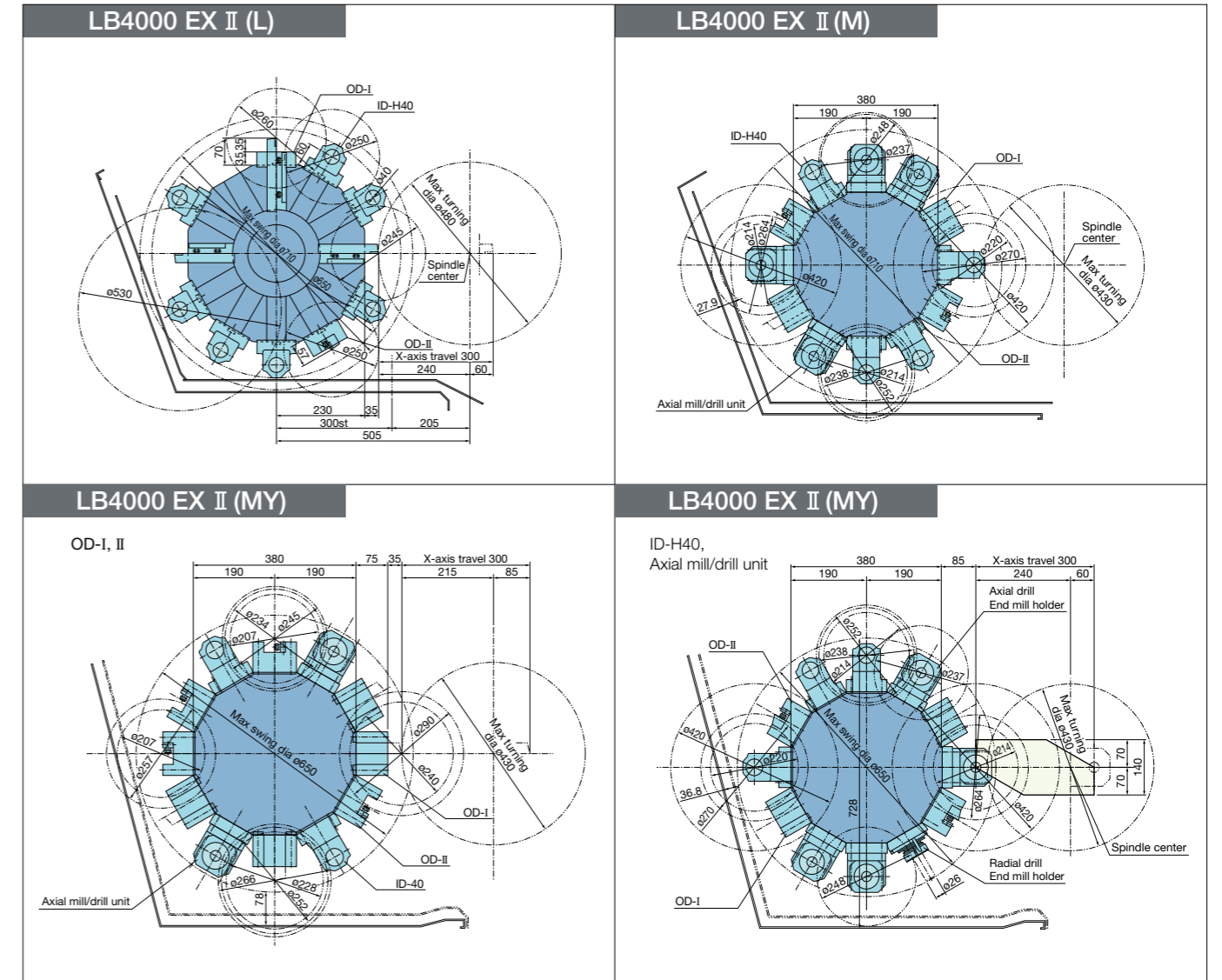

## Various chip conveyors

### Chip conveyor types and application

Type	Hinge	Scraper	Magnet scraper	Hinge + Scraper (with drum filter)
Application	<ul style="list-style-type: none"> <li>For steel</li> </ul>	<ul style="list-style-type: none"> <li>For castings</li> </ul>	<ul style="list-style-type: none"> <li>For castings</li> </ul>	<ul style="list-style-type: none"> <li>For steel, castings, nonferrous metal</li> </ul>
Features	<ul style="list-style-type: none"> <li>General use</li> </ul>	<ul style="list-style-type: none"> <li>Magnet scraper more effective for sludge disposal</li> <li>Easy maintenance</li> <li>Blade scraper</li> </ul>	<ul style="list-style-type: none"> <li>Effective with sludge</li> <li>Not suited for nonferrous metals</li> </ul>	<ul style="list-style-type: none"> <li>Filtration of long and short chips and coolant</li> </ul>
Shape				

Note: Machine platform may be necessary depending on the type of conveyor.

## Working Ranges

Unit: mm

### LB4000 EX II (L)

( ) for C x 1500, [ ] for C x 2000; with different tailstock (minor dimensions may vary)

OD-I

ID-H40

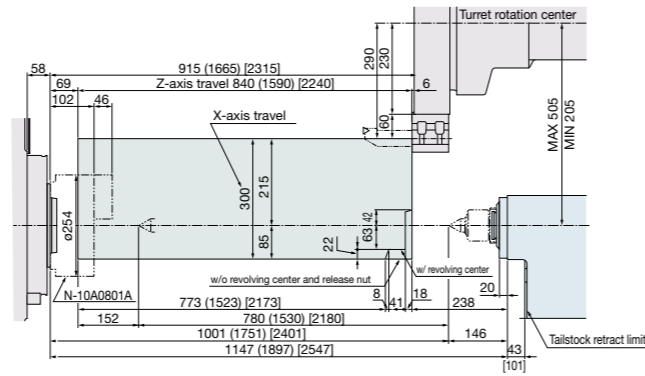
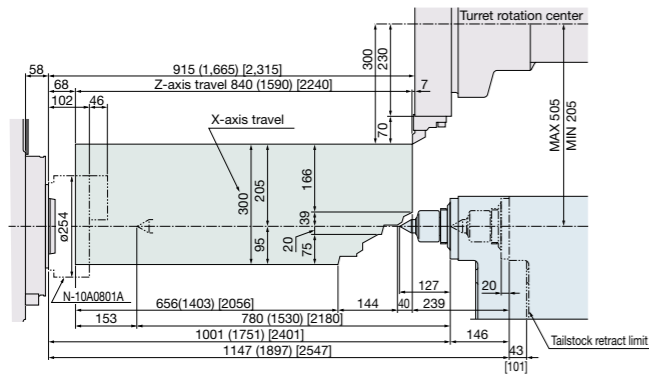

### LB4000 EX II (M, MY)

( ) for C x 1500, [ ] for C x 2000; with different tailstock (minor dimensions may vary)

OD-I

Axial mill / drill unit

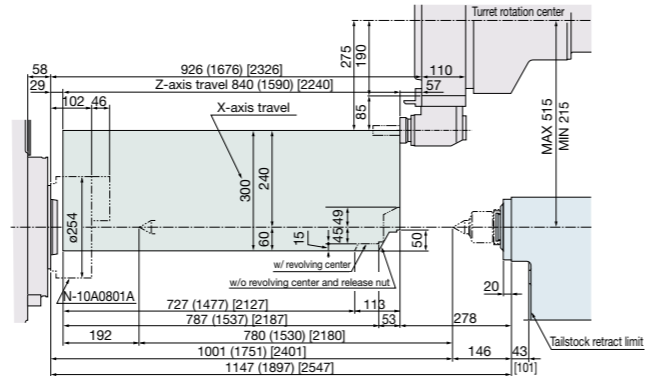
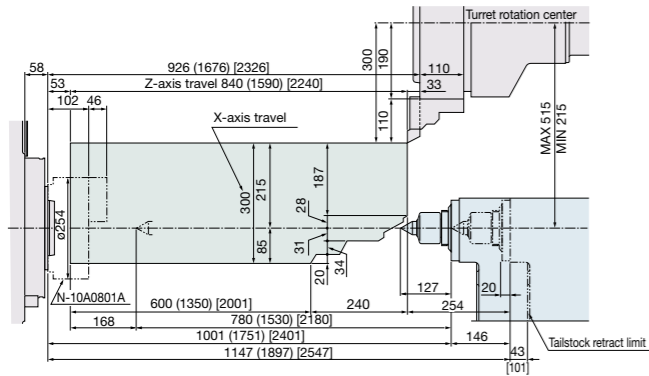

## Optional Specs & Accessories

Headstock	Big-Bore spindle	Lubrication	Lube monitor B-2, C-1, C-2	
	Spindle bearing ID $\phi$ 160		Coolant	Shower coolant A, B
	Spindle motor 37/30 kW (30 min/cont)		Spindle ID coolant A, B	Pump motor: 0.8 kW
Turret	Super Big-Bore spindle	High pressure switch		
	Spindle bearing ID $\phi$ 240	Sludge control		
	Spindle motor 37/30 kW (30 min/cont)	Flow/Level detection		
Chucking	M-V12 turret (VDI)	Mist collector		
	Chuck auto open/close confirm	Coolant gun		
Gauges	Chuck high/low pressure switch	Air	Air blow (blast; chuck, center, spindle ID, turret)	
	Work stopper in spindle	Cover	Front door auto open/close	
Tailstock	Touch Setter M (manual), A (auto)	Chip handling *1	Chip pan side or rear	
	Revolving center: MT No. 5	Chip conveyor side or rear discharge L, H	Chip bucket L, H	
	Tailstock taper: Built-in center MT No. 4	Dustproofing	Air purge, double wiper	
Steadyrests	High thrust specs	Automation	Bar feeder	
	Tailstock thrust high/low switch specs	Bar puller		
	Rollers (fixed position)	NC robots		
	Auto steadyrest (self-centering)	NC loaders		
		Front door with large window *2		

\*1. Rear discharge is not available with C x 1500, C x 2000 specifications  
\*2. Standard for the European market.

## Floor Space

\*  
**5.8m<sup>2</sup>**



**Small machine footprint of \*5.8 m<sup>2</sup> for effective use of plant floor space.**

With a mere \*5.9 m<sup>2</sup> (62 ft<sup>2</sup>) required for installation, workpieces of up to  $\phi$ 480 x 750 mm (18.9 x 29.53 in) can be accommodated. This enables maximum use of limited factory space.

**1,920 mm (74.80 in)** \*When specification for distance between centers is 750

Photo includes some optional specifications.

## Dimensional Drawings

Unit: mm  
( ) dimensions for H chip conveyor

### LB4000 EX II (L / M) Specifications x 750

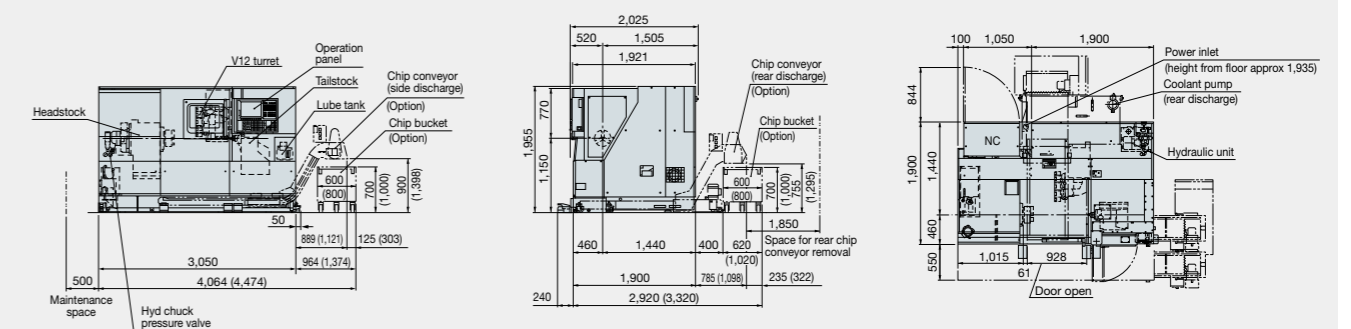

### LB4000 EX II (L / M) Specifications x 1,500

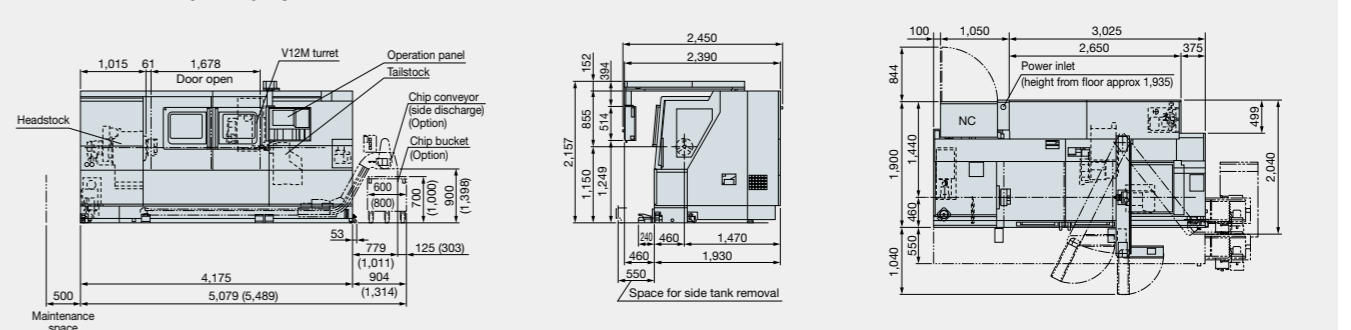

# Dimensional Drawings

Unit: mm  
( ) dimensions for H chip conveyor

## LB4000 EX II (L / M) Specifications × 2,000

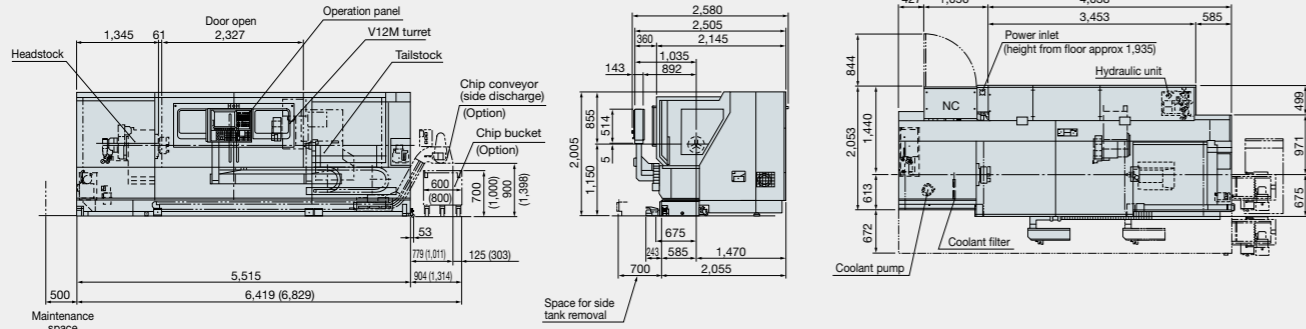

## LB4000 EX II (MY) Specifications × 750

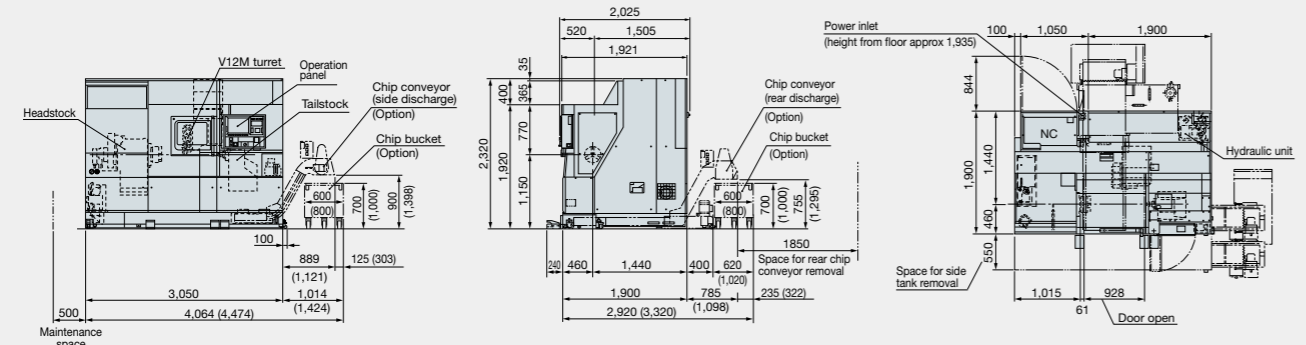

## LB4000 EX II (MY) Specifications × 1,500

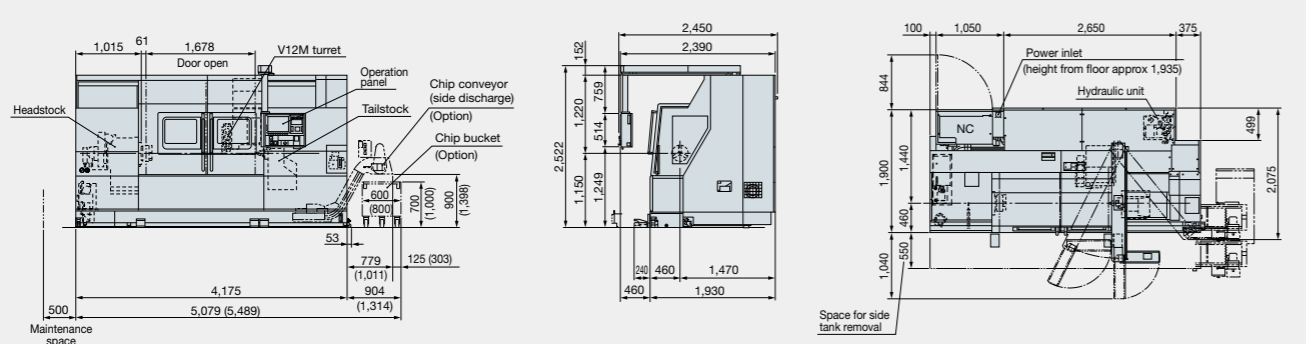

## LB4000 EX II (MY) Specifications × 2,000

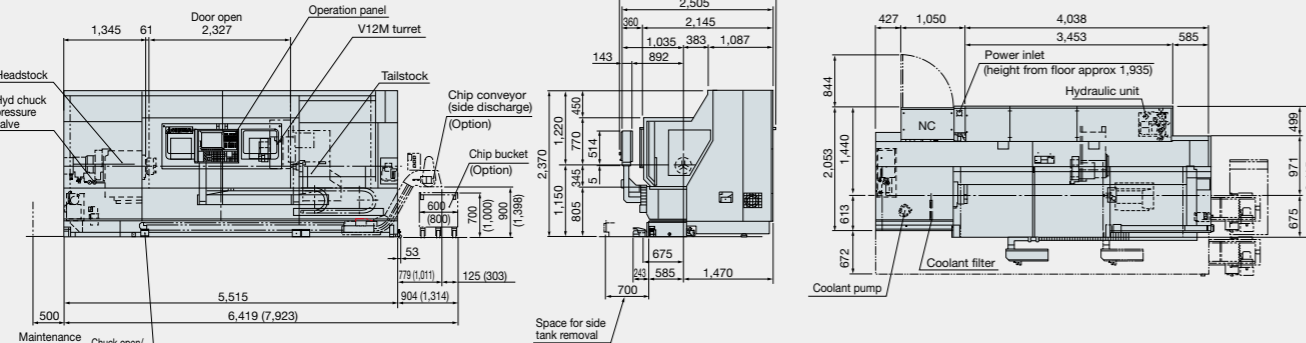

# OSP suite OSP-P300LA

The Next-Generation Intelligent CNC

## Standard Specifications

Basic Specs	Control	Turning: X, Z simultaneous 2-axis, Multitasking: X, Z, C simultaneous 3-axis	
	Position feedback	OSP full range absolute position feedback (zero point return not required)	
	Min / Max command	±99999.999 mm, 99,999.999° 8-digit decimal, command units: 0.001 mm, 0.01 mm, 1 mm, 0.001°, 0.01°, 1°	
	Feed	Override: 0 to 200%	
	Spindle control	Direct spindle speed commands (S4) override	50 to 200%
		Constant cutting speed, optimum turning speed designate	
	Tool compensation	Tool selection: 32 sets, tool offset: 32 sets	
	Display	15-inch color display operational panel + multi touch panel operations	
	Self-diagnostics	Automatic diagnostics and display of program, operation, machine, and NC system problems	
	Program capacity	Program storage: 4 GB, operation buffer: 2 MB	
Operations	"suite apps"	Applications to graphically visualize and digitize information needed on the shop floor	
	"suite operation"	Highly reliable touch panel suited to shop floors. One-touch access to suite apps.	
	Easy Operation	"Single-mode operation" to complete a series of operations. Advanced operation panel/graphics facilitate smooth machine control	
	Programming	Program management, edit, scheduled programs, fixed cycles, special fixed cycles, tool nose R compensation, M-spindle synchronized tapping, fixed drilling cycles, arithmetic functions, logic statements, trig functions, variables, branch statements, auto programming (LAP4), programming help	
	Machine operations	MDI, manual (rapid traverse, pulse handle), load meter, operations help, alarm help, sequence return, manual interrupt & auto return, data I/O, spindle orientation (electric), easy setting of cycle time reduction	
	MacMan	Machining Management: machining results, machine utilization, fault data compile & report, external output	
Communications/Networks	USB (2 ports), Ethernet		
High speed/accuracy	Hi-G control		
Energy-saving function	ECO suite	ECO Idling Stop, ECO Power Monitor	

## Optional Specifications

Item	Kit Specs *1	NML				3D				OT-IGF				OTM			
		E	D	E	D	E	D	E	D	E	D	E	D	E	D		
<b>New Operations</b>																	
Advanced One-Touch IGF-L *2																	
Advanced One-Touch IGF-L Multitasking *2																	
<b>Programming</b>																	
Circular threading																	
Program notes																	
User task 2 I/O variables, 8 each																	
Work coordinate system select	10 sets																
	50 sets																
	100 sets																
Tool compensation (Std: 32 sets)	Tool compensation 64 sets																
	Tool compensation 96 sets																
	Tool compensation 200 sets																
	Tool compensation 999 sets																
Common variables 1,000 pcs (Std: 200 pcs)																	
<b>Thread matching</b>																	
Threading slide hold (G34, G35)																	
Variable Spindle Speed Threading (VSST)																	
Inverse time feed																	
Spindle synchronized tapping (rigid tapping)																	
Milling machine specs	Coordinate convert																
	Profile generate																
	Flat turning																
	3-dimensional coordinate conversion																
<b>Helical cutting (within 360 degrees)</b>																	
<b>Monitoring</b>																	
Real 3-D simulation																	
Cycle time over check																	
Load monitor (spindle, feed axis)																	
Load monitor no-load detection (load monitor ordered)																	
Machine Status Logger																	
AI machine diagnostics (feed axes)																	
Tool life management																	
Tool life warning																	
Operation end buzzer																	
Chucking miss detection																	
Work counters	Count only																
	Cycle stop																
	Start disabled																
Hour meters	Power ON																
	Spindle rotation																
	NC operating																
NC operation monitor (counter, totaling)																	
Status indicator (triple lamp) Type C [Type A, Type B]																	
<b>Measuring</b>																	
In-process work gauging																	
Z-axis automatic zero offset by touch sensor																	
C-axis automatic zero offset by touch sensor																	
Gauge data output	File output																
Post-process work gauging interface	Set levels (5-level, 7-level)																
	BCD																
Touch Setter [M, A]																	

Item	Kit Specs *1	NML				3D				OT-IGF				OTM			
		E	D	E	D	E	D	E	D	E	D	E	D	E	D		
<b>External Input/Output and Communication Functions</b>																	
RS-232C connector																	
DNC link	DNC-T3																
	DNC-C/Ethernet																
	DNC-DT																
USB (additional)	2 additional ports possible																
<b>Automation/Unattended Operation</b>																	
Auto power shutoff: M02, alarm																	
Warm-up function (by calendar timer)																	
<b>Tool retract cycle</b>																	
External program selections	A (pushbutton) 8 types																
	B (rotary switch) 8 types																
	C (digital switch) BCD, 2-digit																
	C2 (external input) BCD, 4-digit																
Okuma loader (OGL) interface																	
Third party robot and loader interface *3	Type B (machine) Type C (robot and loader) Type D Type E																
Bar feeders	Bar feeder																
Cycle time reduction *3	Interface only																
	Operation time reduction																
	Chuck open/close during spindle rotation Tailstock advance/retract during spindle rotation																
<b>High-Speed/High-Accuracy Functions</b>																	
1/10 μm control *3																	
Pitch error compensation																	
AbsoScale detection *3																	
Hi-Cut Pro																	
<b>ECO suite (energy saving function)</b>																	
ECO Operation	Chip conveyor intermit/link op																
	Mist collector intermit/link op																
	Spindle Power Peak Limiter																
<b>Other Functions</b>																	
Collision Avoidance System (CAS)																	
One-Touch Spreadsheet																	
Machining Navi L-gII																	
Machining Navi T-g (Threading)																	
Harmonic Spindle Speed Control (HSSC)																	
Spindle dead-slow cutting																	
Spindle speed setting																	
Spindle S command 0.1 min <sup>-1</sup>																	
Manual cutting feed																	
Short circuit breaker																	
External M signals [2 sets, 4 sets, 8 sets, 16 sets]																	
Edit interlock																	
OSP-VPS (virus protection system)																	

\*1. NML: Normal, 3D: Real 3D simulation, OT-IGF: One-Touch IGF, OTM: One-Touch M  
E: Economy, D: Deluxe  
\*2. Real 3-D Simulation included  
\*3. Engineering discussions required.  
Note: ▲ Triangle items for M function (milling tool) machines only.

When using Okuma products, always read the safety precautions mentioned in the instruction manual and attached to the product.

● The specifications, illustrations, and descriptions in this brochure vary in different markets and are subject to change without notice.  
Pub No. SPACE TURN LB4000 EXII-E-(16a)-400 (Sep 2020)



**OKUMA Corporation**

Oguchi-cho, Niwa-gun,  
Aichi 480-0193, Japan  
TEL: +81-587-95-7825 FAX: +81-587-95-6074

---

This product is subject to the Japanese government Foreign Exchange and Foreign Trade Control Act with regard to security controlled items; whereby Okuma Corporation should be notified prior to its shipment to another country.