

# ***MILLAC VH Series***

***MILLAC 800VH  
MILLAC 1000VH***

Large 5-Axis Machining Centers



# MILLAC VH Series

Large 5-Axis Machining Centers

*MILLAC 800VH / MILLAC 1000VH*



## 5-axis machining centers with a swivel spindle to machine inclined surfaces

In addition to top surface machining on the vertical axis and side surface machining on the horizontal axis, a swivel spindle with 0.001° indexing allows machining of any slope.

One-chuck multi-sided machining provides improved accuracy, reduced tool change time, and significant increases in productivity.

The table remains horizontal while the spindle tilts. This means there is no movement in the center of gravity of large workpieces. Interference checks with the head is simplified.



**MILLAC 1000VH**

Photos shown in this brochure include optional equipments.

# Heavy-duty cutting and high accuracy— Basic structure to significantly improve productivity of large part machining

## MILLAC 800VH

Solid structure with box-type bed and wide box way. Stable accuracy is maintained with large-diameter, pre-tensed ball screw. Rapid feedrate of 30 m/min and fast ATC, APC movements gives nimble, efficient production.

## MILLAC 1000VH

Double column construction that resists bending and twisting is used to maintain stable accuracies over long times. The crossrail uses a combination of slide and rollers for smooth movement and high-accuracy positioning.

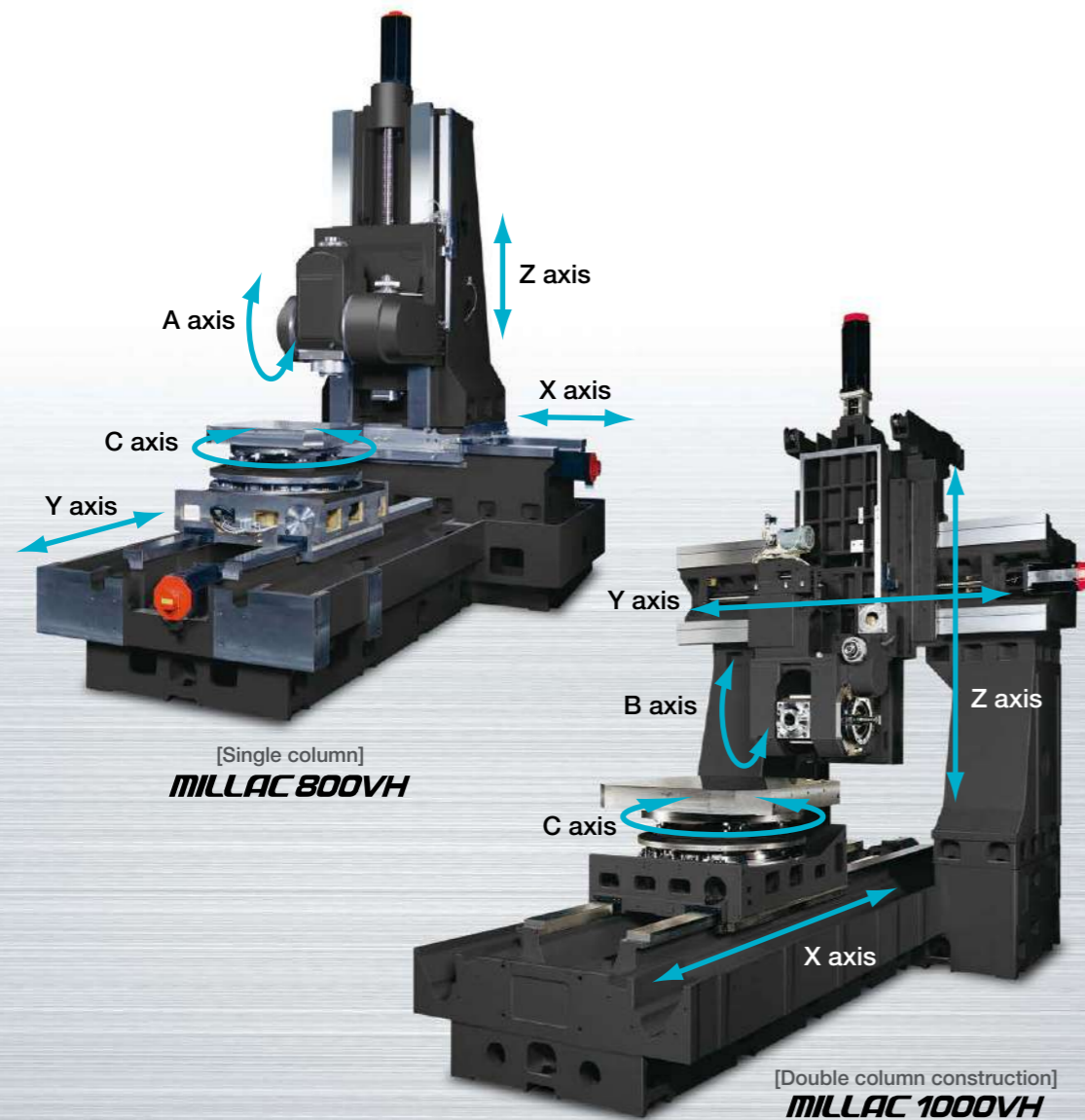

## Spindle

The No. 50 spindle uses a highly rigid bearing for smooth construction, achieving a balance between nimble startup and high accuracy.

Two types of spindle, built-in and gear head, are available depending on use. With high torque and output from low to high speeds, operations from small diameter end milling to large diameter face milling can be easily handled.

	Spindle speed	Motor output
MILLAC 800VH MILLAC 1000VH (Integral motor/spindle)	100 to 10,000 min <sup>-1</sup>	22/18.5 kW (30/25 hp)
MILLAC 1000VH (Gear head)	20 to 6,000 min <sup>-1</sup>	22/18.5 kW (30/25 hp)

\* On the MILLAC 1000VH, the integral motor/spindle is optional.  
The MILLAC 800VH does not have a gear head option.

Swivel spindle can be set at any position of 0.001°, and hydraulically clamped (braked).

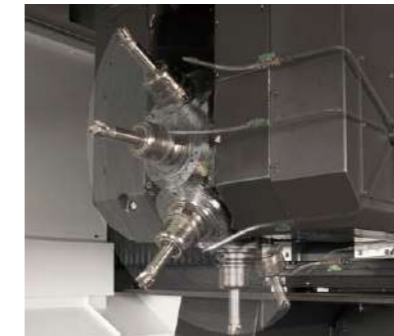

## High-rigidity

The slideway on each axis is a box way coated with special resin, combining good damping properties, high rigidity, and smooth movement.

## Ease of use

The operation panel is located next to the machine side door for better visibility of the spindle and workpiece and efficient work. An easy-to-use, mobile pulse handle is standard equipment.

## Other equipment

Standard full-enclosure shielding ensures a high level of safety and good factory environment.

A large oil pan, large capacity coolant tank, and chip conveyor positioned on the right and left of the table provide for outstanding chip discharge.

## Pallet

In addition to continuous machining and multi-sided machining with NC indexing, the pallet can be clamped with curvic coupling every 5° for outstanding heavy-duty cutting of large and heavy workpieces. (Clamp torque 12,000 N-m)

Scale feedback standard on pallet rotation axis (C axis). (MILLAC 800VH only)

	Pallet dimensions	Max pallet loading capacity
MILLAC 800VH	800 × 800	1,000 kg
MILLAC 1000VH	1,000 × 1,000	2,000 kg



# Machining center with the best accumulation of functions for improving accuracy of intricate shapes

## Process-intensive applications and machining of complicated workpieces with 5-axis control

With large working range and a swivel spindle, the side and top surfaces can be machined, in addition to any inclined surface. Even workpieces with complex shapes that previously had to be machined in many separate processes can now be machined with a single setup for process-intensive machining.

The time for prepping work is minimized and product accuracy is improved since no error is produced from mounting and dismounting.

### Machining example

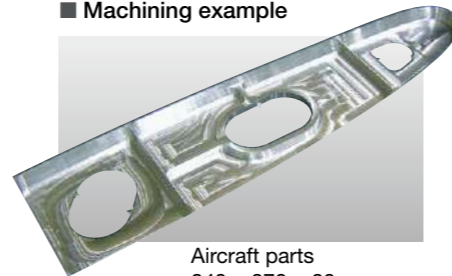

Aircraft parts  
840 × 370 × 30 mm  
(33.07 × 14.57 × 1.18 in)

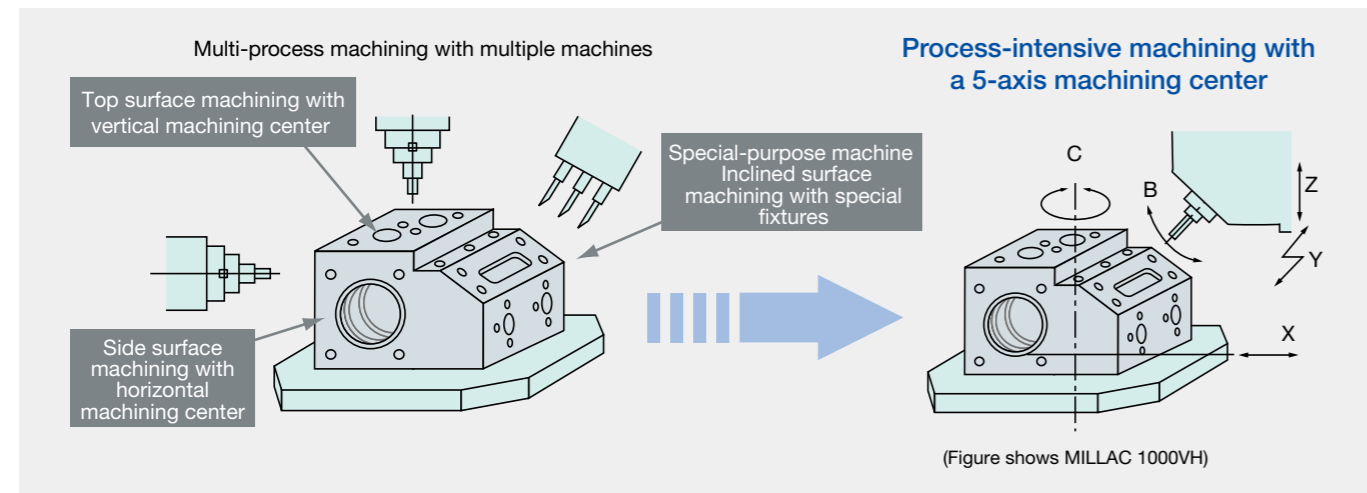

(Figure shows MILLAC 1000VH)

## Shorter cycle times

Cycle times can be greatly reduced by avoiding machining with a ball-nose end mill at a cutting speed of zero and tilting the tool axis when cutting straight portions with a side cutting edge.

Cutting can also be done on rigid surfaces with short tools, which have superior tool life, and at angles that avoid interference.

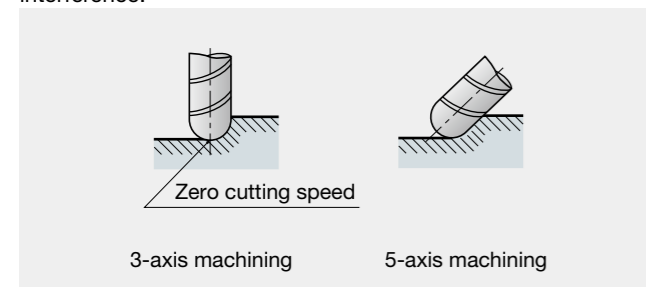

## Lower tool costs

When a tool is angled out of perpendicular to the work surface, cutting efficiency and tool life are increased by being able to put more teeth into the cut and eliminating the zero cutting speed condition inherent with ball end mills. Tool life is increased and tooling costs are ultimately reduced.

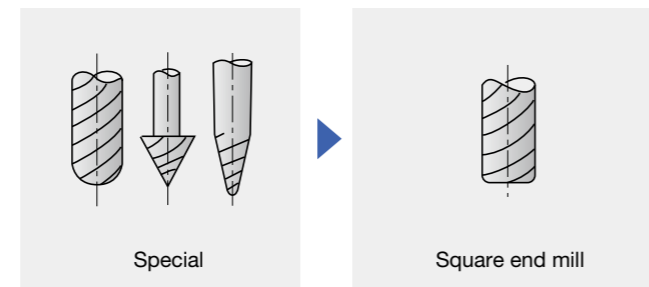

# Many easy-to-use functions that utilize 5-axis control

## Manual pulse handle feed along tool axis and perpendicular to surface

With the tool axis at an angle, handle feed can be done along and perpendicular to the axis. With this function, drilling on a slope, tool relief, and flat surface machining on slopes can be done easily with a pulse handle.

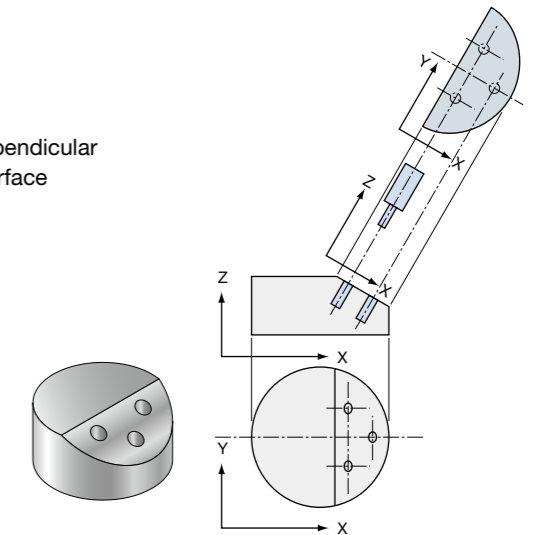

## 3-dimensional coordinate conversion

Programs for things such as drilling holes in slopes or shape machining need only programming on the X-Y plane program. Coordinates around the axis can be set freely by commands for the center, direction, and angle of coordinate rotation.

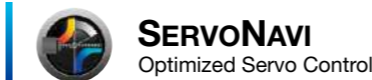

Achieves long term accuracy and surface quality

## SERVONAVI AI (Automatic Identification)

- **Work Weight Auto Setting**  
Cycle time shortened with faster acceleration

On table travel type machining centers, the table feed acceleration with the previous system was the same regardless of weight, such as workpieces and fixtures loaded on the table.

Work Weight Auto Setting estimates the weight of the workpiece and fixture on the table and automatically sets the linear axis servo parameters, including acceleration, to the optimum values. Cycle times are shortened with no changes to machining accuracy.

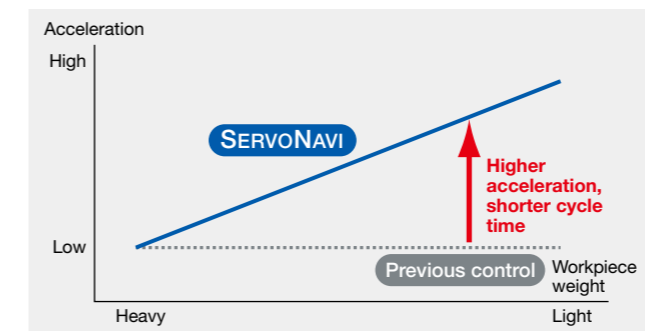

- **Rotary Axis Inertia Auto Setting**  
Maintains high accuracy and stable movements

Depending on the workpiece or fixtures, inertia will vary, and with each variation the positioning error in some cases became much larger.

Rotary Axis Inertia Auto Setting is able to estimate inertia from workpiece/fixture acceleration and deceleration, and automatically set the optimum the rotary axis servo parameters to maintain highly accurate and stable machine movements.

## SERVONAVI SF (Surface Fine-tuning)

- **Reversal Spike Auto Adjustment**  
Maintains machining accuracy and surface quality

Slide resistance changes with length of time machine tools are utilized, and discrepancies occur with the servo parameters that were the best when the machine was first installed. This may produce crease marks at motion reversals and affect machining accuracy (part surface quality).

SERVONAVI's Reversal Spike Auto Adjustment maintains machining accuracy by switching servo parameters to the optimum values matched to changes in slide resistance.

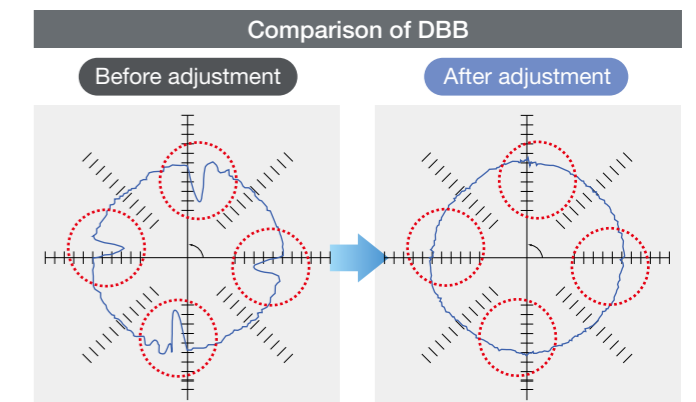

- **Vibration Auto Adjustment** Contributes to longer machine life

When aging changes machine performance, noise, vibration, crease marks, or fish scales may appear.

Vibration Auto Adjustment can quickly eliminate noise and vibration even from machines with years of operation.

## Machine Specifications

Item		Unit	MILLAC 800VH	MILLAC 1000VH
Travel	X axis	mm (in)	Column horizontal: 1,020 (40.16)	Column horizontal: 1,850 (72.83)
	Y axis	mm (in)	Pallet front/back: 1,020 (40.16)	Pallet front/back: 1,300 [1,600] (51.18 [62.99])
	Z axis	mm (in)	Spindlehead vertical: 1,020 (40.16)	Spindlehead vertical: 1,000 (39.37)
	Spindle nose to pallet top (vertical)	mm (in)	-100 to 920 (-3.94 to 36.22)	-100 to 900 (-3.94 to 35.43)
	Spindle center to pallet center (vertical)	mm (in)	-50 to 970 (-1.97 to 38.19)	-580 to 1,270 (-22.83 to 50)
	Spindle center to pallet top (horizontal)	mm (in)	150 to 1,170 (5.91 to 46.06)	150 to 1,150 (5.91 to 45.28)
	Spindle nose to pallet center (horizontal)	mm (in)	-300 to 720 (-11.81 to 28.35)	-830 to 1,020 (-32.68 to 40.16)
Table	Max work dimension	mm (in)	800 x 800 (31.49 x 31.49)	1,000 x 1,000 (39.37 x 39.37)
	Max load capacity*	kg (lb)	1,000 (2,200)	2,000 (4,400)
	Indexing angle (curvic coupling orientation)	deg		5
	Indexing angle (any NC orientation)	deg		0.001
Spindle	Floor to pallet top	mm (in)	1,230 (48.43)	1,290 (50.79)
	Speed	min <sup>-1</sup>	100 to 10,000	20 to 6,000 [100 to 10,000]
	Tapered bore			No. 50
	Swivel angle	deg		150
	Indexing angle (curvic indexing)	deg		5
Axis feed	Indexing angle (NC arbitrary indexing)	deg		0.001
	Rapid traverse	m/min (ipm)	X-Y-Z: 30 (1,181)	X-Y: 24 (949), Z: 12 (472)
	Rapid traverse	min <sup>-1</sup>	A-C: 3,600	B-C: 1,440
	Cutting feed rate	mm/min (ipm)	X-Y-Z: 1 to 12,000 (0.04 to 472)	X-Y-Z: 1 to 10,000 (0.04 to 394)
Motors	Cutting feed rate	deg/min	A-C: 1 to 2,400	B-C: 1 to 1,080
	Spindle	kW (hp)	22/18.5 (30/25) (15 min/cont)	22/18.5 (30/25) (30 min/cont) [22/18.5 (30/25) (15 min/cont)]
	Feed axes (X/Y/Z)	kW (hp)	OSP X: 5.6 (7.5), Y: 3.5 (4.7), Z: 5.6 (7.5) FANUC X-Y: 7.0 (9.3), Z: 6.0 (8)	OSP X-Y-Z: 4.6 (6.1) FANUC X-Y: 7.0 (9.3), Z: 6.0 (8)
	Spindle swivel servo motor	kW (hp)	OSP: 3.5 (4.7) FANUC: 3.0 (4)	OSP: 3.5 (4.7) FANUC: 4.0 (5.3)
ATC	Table indexing servo motor	kW (hp)	OSP: 3.5 (4.7) FANUC: 3.0 (4)	OSP: 3.6 (4.8) FANUC: 7.0 (9.3)
	Tool shank		MAS BT50	
	Pull stud		MAS 2	
	Tool capacity	tool	80 [120]	40 [60, 80, 120]
	Max tool dia (w/adjacent tool)	mm (in)	ø125 (4.92)	ø120 (4.72)
	Max tool dia (w/o adjacent tool)	mm (in)	ø200 (7.87)	ø200 [ø240] (7.87 [9.45])
	Max tool length/mass	mm/kg	400/20	400 [500] / 20 [25]
	Max tool moment	N-m (ft-lbf)	14.7 (10.84)	19.6 [44.1] (14.45 [32.52])
	Tool selection		Fixed address	
	Tool change time (T-T)	sec	4.5	8
APC	APC		2-pallet rotary-shuttle automatic pallet changer	
	APC time	sec	20	30
Size	Effective width between columns	mm (in)	-	1,250 (49.21)
	Machine height	mm (in)	OSP: 3,600 (141.73)	OSP: 4,455 (175.39)
	Machine weight Width x depth	mm (in)	OSP: 4,760 x 6,390 (187.40 x 251.57) (step excluded)	OSP: 5,228 x 7,117 [5,613 x 7,315] [205.83 x 280.20 [220.98 x 287.99]]
	Mass	kg (lb)	22,000 (48,400)	25,000 (55,000)
Controller	Power capacity	kVA	60	OSP: 51.1, FANUC: 61
			OSP-P300MA, FANUC 31i-B5	

Note: Tool change time shown is that measured under JIS B6013 conditions (horizontal machining center). [ ]: Optional

\* When change the pallets uses difference of less than 1,000 kg in loading mass on pallets A and B.

## Spindle output/torque diagram

**MILLAC 800VH** (Standard)  
**MILLAC 1000VH** (Optional)  
**(OSP)**

Spindle speed: 10,000 min<sup>-1</sup>  
Motor output: 22/18.5 kW (30/25 hp) (15 min/cont)  
Torque: 165 N-m (121.70 ft-lbf) (25% ED)

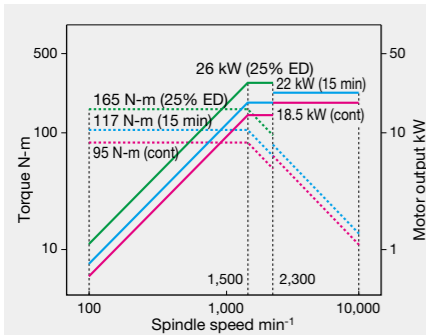

**MILLAC 800VH** (Standard)  
**MILLAC 1000VH** (Optional)  
**(FANUC)**

Spindle speed: 10,000 min<sup>-1</sup>  
Motor output: 22/18.5 kW (30/25 hp) (15 min/cont)  
Torque: 167 N-m (122.79 ft-lbf) (25% ED)

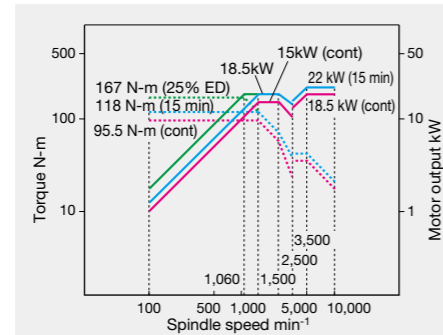

**MILLAC 1000VH** (Standard)  
**(OSP-FANUC)**

Spindle speed: 6,000 min<sup>-1</sup>  
Motor output: 22/18.5 kW (30/25 hp) (30 min/cont)  
Torque: 525 N-m (386.03 ft-lbf) (30 min)

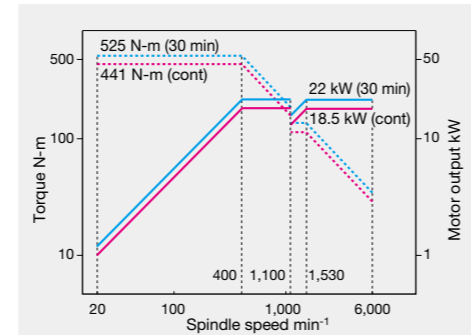

## Standard Specifications & Accessories

Item	MILLAC 800VH	MILLAC 1000VH
Simultaneously 5-axis control	○	(Simultaneous 4-axis: standard)
Spindle speed	10,000 min <sup>-1</sup> , 22/18.5 kW (30/25 hp) integral motor/spindle, oil-mist lubrication spindle air curtain available	6,000 min <sup>-1</sup> , 22/18.5 kW (30/25 hp) 2-speed gear spindle, oil-mist lubrication
Dual contact spindle (BIG-PLUS®)		○
B-axis curvic coupling	-	○
Spindle cooling system	Oil controller	
Automatic pallet changer	2-pallet rotary-shuttle, machine front face installation	
Pallets	800 x 800 mm, 2 pallets, M16 top surface tap	1,000 x 1,000 mm, 2 pallets, M16 top surface tap
ATC tool storage capacity	80 tools	40 tools
Coolant system	1,200-L tank 1.1-kW pump motor 4 universal nozzles	900-L tank 1.1-kW pump motor 3 universal nozzles
Hydraulic unit		○
Machine shielding	Full enclosure shielding with ceiling	
Electromagnetic locks	Operator's door, APC shield, magazine door	
Work lamp		LED
Slideway lubricating system		○
ATC air blower (blast)		○
Tool kit		○
Tool release lever		○
AbsoScale detection (2 rotational axes) (OSP)	○	-
Scale feedback (2 rotational axes) (FANUC)	○	-
Jack bolts, foundation blocks		○
CNC	OSP-P300MA or FANUC 31i-B5	
Operation panel with color LCD		○
Pulse handle		Portable 1-axis switch

**Chip Conveyor** Please contact an Okuma sales representative for details.

**Recommended chip conveyor**

○: Recommended △: Available

Material	Steel	FC	Aluminum/Nonferrous	Mixed (general use)
Chip shape				
In-machine	MILLAC 800VH: Coil MILLAC 1000VH: Screw	○	○	○
Off-machine	Hinge	○	-	△ (*4)
	Scraper	-	○ (Dry)	-
	Scraper (with drum filter)	-	○ (Wet) with magnets	△ (*3)
	Hinge + scraper (with drum filter)	△ (*1)	△ (Wet) (*2)	○

\*1. When there are many fine chips \*2. When chips are longer than 100 mm \*3. When chips are shorter than 100 mm \*4. When there are few fine chips

Note: When dry-cutting be sure to clean away chips that have accumulated under the pallet or elsewhere in the machine as needed.

The machine may need to be raised (platform) depending on the type of chip conveyor.

**Off machine lift-up chip conveyors**

Item	Hinge	Scraper	Scraper (with drum filter)	Hinge + scraper (with drum filter)
Shape				

## Optional Specifications & Accessories

Item	MILLAC 800VH	MILLAC 1000VH
Spindle speed	—	100 to 10,000 min <sup>-1</sup> (integral)
Axis travel	—	Y axis: 1,600 mm
Simultaneous 5-axis control	(Standard)	
APC variations	6-pallet APC, 8-pallet APC, multi-pallet APC	4-pallet APC, 6-pallet APC, 8-pallet APC, multi-pallet APC
Pallet upper surface	T-slot, 18 mm	
Fixture mount/pallet alignment pin	Foot switch	
Thru-spindle coolant *1	1.5 MPa, 3.5 MPa, 7.0 MPa (back filter mounted separately)	
Thru-spindle semi-dry unit	Preps	
Pallet size	630 × 630 mm (non 2-APC)	ø1,250 mm
ATC tool magazine capacity	120 tools	60, 80, 120 tools
Status indicator	3-color C type (signal tower)	
Shower coolant system	Ceiling shower (additional pump)	
In-machine chip discharge (gutter)	Coils (1 left and 1 right)	Screws (1 left and 1 right) (Standard)
In-machine chip discharge (oil pan)	Chip flusher	
Off-machine chip discharge	Various lift-up chip conveyors (see p. 8)	
Chip bucket for above	With tilt: H800, without tilt: H700	
Pull stud shape	MAS 1, 90°	
Chip air blower (blast)	Nozzle type	
Workpiece washing gun	Main operation panel door side and APC door side	Main operation panel door side and APC door side, Main operation panel door side
Air gun	Main operation panel door side and APC door side	Main operation panel door side and APC door side, Main operation panel door side
Coolant pump	2.2 kW	
Coolant sensors	Level sensor (lower limit only)	
Coolant temperature regulator	Heating and cooling	
Oil skimmer	Belt system	
Oil mist coolant		
Mist collector (Akamatsu Denki)	HVS-220	HVS-2500
Raised machine setup		
High column	—	250 mm (spacer system)
Spindle nose rotate stopper	P = 80 mm, BIG-PLUS® compatible	
AbsScale detection (OSP)	X, Y, Z axes	2 rotary axes, 2 rotary + X-Y-Z axes
Scale feedback (FANUC)	X, Y, Z axes	2 rotary axes, 2 rotary + X-Y-Z axes
Foundation bolts	6 holed foundation blocks and foundation bolts, 6 holed foundation blocks and chemical anchors, clamp anchors (4 locations)	
Control cabinet temperature regulator		
Automatic tool length compensation *2	Stationary touch sensor, mobile touch sensor	Stationary touch sensor
Reference tool (No. 50)		
Auto gauging *3	FM radio	
Ring gauge		
Full enclosure shielding with ceiling	—	Att head travel & head full enclosure shielding
Angular attachment head preps	—	Block only (P = 110 mm*4, BIG-PLUS® compatible)

\*1. Dedicated Okuma pull stud required for thru-spindle coolant \*2. Including breakage detection \*3. Including zero point compensation \*4. ATC is not available when P = 110 mm.

## Cutting capability

■ Integral motor/spindle With 10,000 min<sup>-1</sup> spindle (Standard on MILLAC 800VH, Optional on MILLAC 1000VH)

Tool	Spindle speed min <sup>-1</sup>	Cutting speed m/min (ipm)	Feedrate mm/min (ipm)	Cutting width mm (in)	Depth of cut mm (in)	Chips cm <sup>3</sup> /min (in. <sup>3</sup> /min)
ø100 face mill 5-blade	500	160 (6,299)	550 (21.65)	70 (2.76)	5 (0.20)	193 (12)

■ Gear head spindle With 6,000 min<sup>-1</sup> spindle (Standard on MILLAC 1000VH)

Tool	Spindle speed min <sup>-1</sup>	Cutting speed m/min (ipm)	Feedrate mm/min (ipm)	Cutting width mm (in)	Depth of cut mm (in)	Chips cm <sup>3</sup> /min (in. <sup>3</sup> /min)
ø125 face mill 6-blade	300	120 (4,724)	800 (31.49)	90 (3.54)	5 (0.20)	360 (21)

## Working ranges

Unit: mm (in)

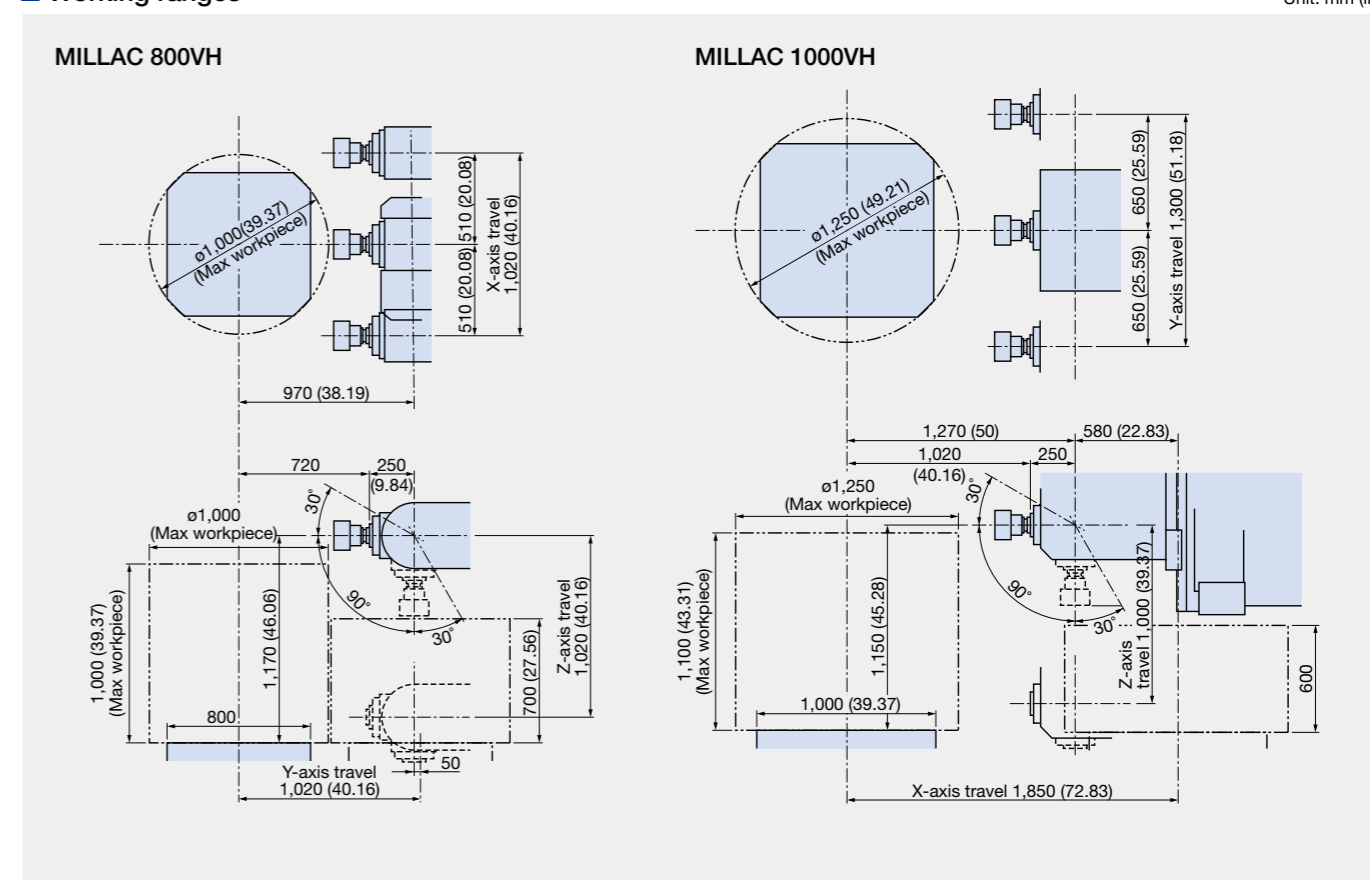

## Pallet dimensions

Unit: mm

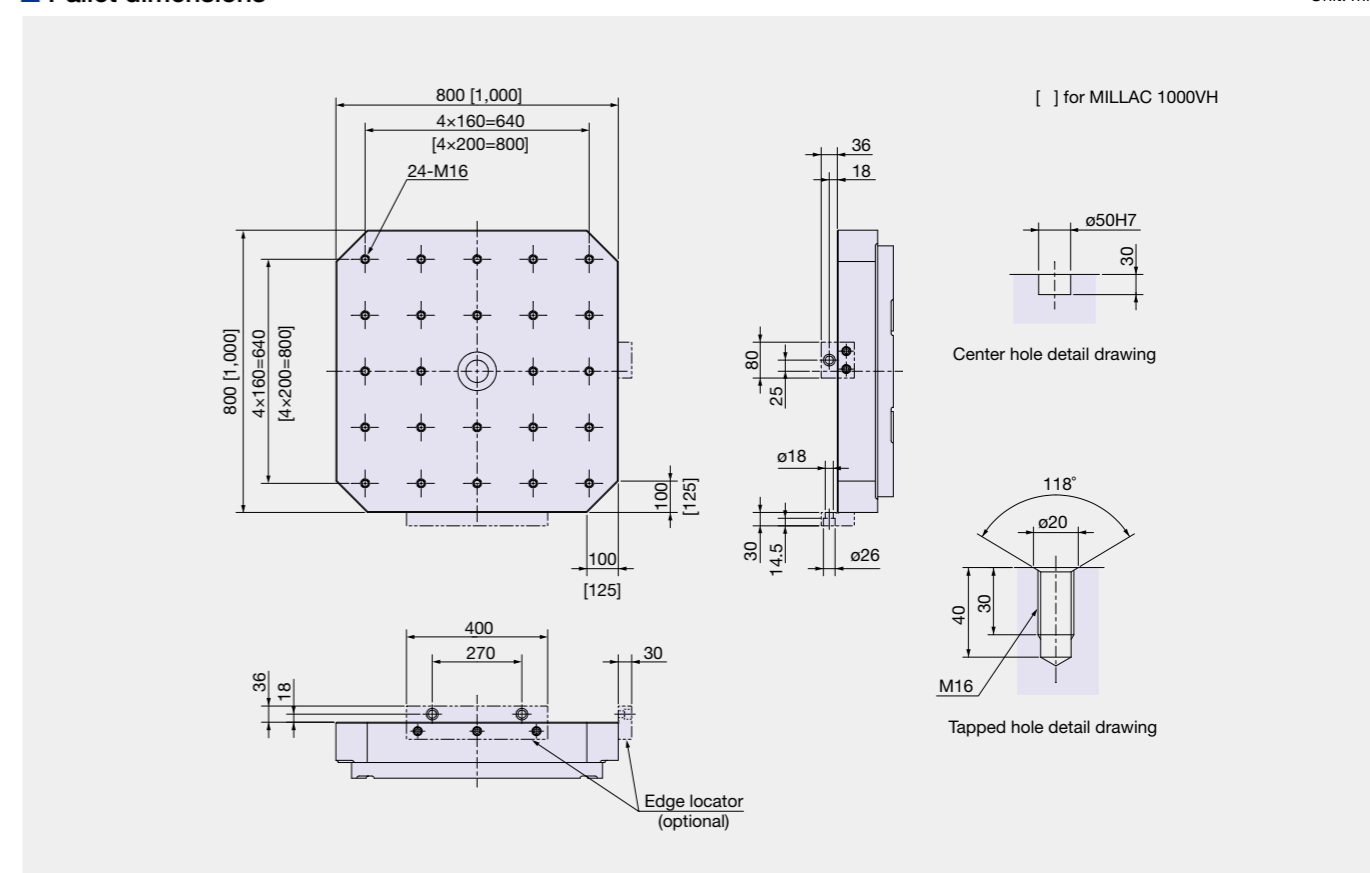

# Okuma Control OSP-P300MA

## Standard Specifications

Basic Specs	Control	MILLAC 800VH: X, Y, Z, A, C axes (5 axes simultaneously), spindle control (1 axis) MILLAC 1000VH: X, Y, Z, B, C axes (4 axes simultaneously), spindle control (1 axis)
	Position feedback	OSP full range absolute position feedback (zero point return not required)
	Coordinate functions	Machine coordinate system (1 set), work coordinate system (20 sets)
	Min / Max command	±99999.999 mm, ±9999.9999° 8-digit decimal, command unit: 0.001 mm, 0.01 mm, 1 mm, 0.0001°, 0.001°, 1°
	Feed	Cutting feed override 0 to 200%, rapid traverse override 0 to 100%
	Spindle control	Direct spindle speed commands override 30 to 300%, multi-point indexing
	Tool compensation	No. of registered tools: Max 999 sets, tool length/radius compensation: 3 sets per tool
	Display	15-inch color LCD + multi-touch panel operations
	Self-diagnostics	Automatic diagnostics and display of program, operation, machine, and NC system faults
	Programming	Program capacity
Program operations		Program management, editing, scheduled program, fixed cycle, G-/M-code macros, arithmetic, logic statements, math functions, variables, branch commands, coordinate calculate, area machining, coordinate convert, programming help
Operations	"suite apps"	Applications to graphically visualize and digitize information needed on the shop floor
	"suite operation"	Highly reliable touch panel suited to shop floors. One-touch access to suite apps.
	Easy Operation	"Single-mode operation" for a series of operations for a single screen Easy-to-use operation panel supports complete machine control
	Machine operations	MDI, manual (rapid traverse, manual cutting feed, pulse handle), load meter, operation help, alarm help, sequence return, manual interrupt/auto return, pulse handle overlap, parameter I/O, PLC monitor, easy setting of cycle time reduction
	MacMan	Machining management: machining results, machine utilization, fault data compile & report, external output
Communications / Networking	USB (2 ports), Ethernet	
High speed/accuracy specs	Hi-G Control, Hi-Cut Pro, pitch error compensation, SERVO NAVI	
Energy-saving function	ECO Idling Stop, ECO Power Monitor*	

\* The power display shows estimated values. When precise electrical values are needed, select the wattmeter option.

## Optional Specifications

Item	Kit Specs	3D		AOT	
		E	D	E	D
<b>Interactive functions</b>					
Advanced One-Touch IGF-M (Real 3D simulation included)				●	●
Interactive MAP (I-MAP)		●	●		
I-MAP-B					
I-MAP-C					
<b>Programming</b>					
Auto scheduled program update		●	●	●	●
Common variables (Std: 200 pcs)	1,000 pcs				
	2,000 pcs				
Program branch	2 sets				
Program notes (MSG)				●	●
Coordinate system selection (Std: 20 sets)	100 sets	●	●		
	200 sets			●	●
	400 sets				
Helical cutting (within 360°)		●	●	●	●
3D circular interpolation					
Synchronized Tapping II		●	●	●	●
Arbitrary angle chamfering		●	●	●	●
Cylindrical side facing					
Slope machining					
Tool max rotational speed setting					
F1-digit feed	4 sets, 8 sets, parameter				
Programmable travel limits (G22, G23)		●	●	●	●
Skip (G31)					
G-/M-code macros					
3D tool compensation					
Tool wear compensation		●	●		
Drawing conversion	Programmable mirror image (G62)			●	●
	Enlarge/reduce (G50, G51)			●	●
User task 2	I/O variables, 16 each				
Fixture offset					
Attachment rotation compensation					
Alignment compensation					
Tool length compensation (axial)					
Tool Center Point Control II (TCP)					
Tool side offset					
Leading edge offset					
Inverse time feed					
<b>Monitoring</b>					
Real 3D simulation		●	●	●	●
Simple load monitor	Spindle overload monitor	●	●	●	●
NC operation monitor	Hour meter, work counter	●	●	●	●
Hour meters	Power, spindle, NC, cutting				
Work counter	With M02 and M30 commands				
<b>Machine Status Logger</b>					
Cutting Status Monitor					
AI Machine Diagnosis Function	Feed axes				
MOP-TOOL	Adaptive control, overload monitor				
Tool life management	Hour meter, No. of workpieces	●	●	●	●

Item	Kit Specs	3D		AOT	
		E	D	E	D
<b>Gauging</b>					
Auto gauging	Touch probe (G31)				
Auto zero offset	Includes auto gauging				
Tool breakage detection	Touch sensor (G31) Includes auto tool offset				
Gauging data printout	File output				
Manual gauging (w/o sensor)		●	●	●	●
Interactive gauging (touch sensor, touch probe required)					
<b>External I/O, communications</b>					
RS-232C connector					
DNC-B (RS-232C-Ethernet transducer used on OSP side)					
DNC-DT					
DNC-C/Ethernet					
Additional USB (additional 2 ports, std: 2 ports)					
<b>Automation, unattended operation</b>					
Auto power shut-off	M02 and END alarms Work preps done → OFF	●	●	●	●
Warm-up (calendar timer)					
External program selection	Button, rotary switch, digital switch, BCD (2-digit, 4-digit)				
Cycle time reduction (Ignores certain commands)					
<b>High-speed, high-precision</b>					
AbsoScale detection	X-Y-Z axes, 2 rotating spindles				
Super-NURBS*					
<b>ECO suite (energy saving functions)</b>					
ECO Operation					
ECO Power Monitor	On-machine wattmeter				
Energy-saving hydraulic unit	Inverter				
<b>Other</b>					
Control cabinet lamp (inside)					
Circuit breaker					
Sequence operation	Sequence stop	●	●	●	●
Upgraded sequence restart	Mid-block return			●	●
Manual angle feed/arc feed					
Manual tool feed (axial)					
Manual tool feed (right angle)					
Tool tip center manual feed					
External M code	4-point, 8-point				
Collision Avoidance System*					
Machining Navi <sup>†</sup> M-g II <sup>‡</sup> , M-g II <sup>‡</sup> (cutting conditions search)					
One-Touch Spreadsheet					
Block skip; 3 sets					
OSP-VPS (Virus Protection System)					

Note: 3D: Real 3D simulation, AOT: Advanced One-Touch IGF-M, E: Economy, D: Deluxe  
 \* There are limitations when Super-NURBS and Collision Advance System are used simultaneously.  
 †1. Harmonic Spindle Speed Control available only with Machining Navi M-g II + specifications.  
 ‡2. Machining Navi M-g II + is available with integral motor/spindles.  
 ‡3. Machining Navi M-g II is available with gear spindles.

# FANUC 31i-B5

## Standard Specifications

Basic Specs	Control	MILLAC 800VH: X, Y, Z, A, C axes (5 axes simultaneously) MILLAC 1000VH: X, Y, Z, B, C axes (4 axes simultaneously)	
	Input increment	±99999.999mm to 0.001mm, 0.001°	
	Workpiece coordinate system	G52 (local CS), G53 (machine CS select), G54 to G59 (work CS, 6 sets)	
	Feed	F5 digit direct command, feedrate override 0 to 200%, rapid traverse override 0 to 100%	
	Spindle control	S5 digit direct command, spindle override 50 to 150%	
	Tool compensation	32 sets (tool comps)	
	Display	10.4-inch color LCD, English display, graphic display	
	Programming	Program capacity	Program capacity: 64 KB (160 m)
		Programming	Number of registerable programs: 63, programmable data input Fixed cycle, tool length measurement Extension program editing, coordinate rotation, tilted working plane indexing Optional block skip (1)
	Operations		Pulse handle, input/output interface, 3-dimensional handle feed
		Self-diagnostics, alarm buzzer	
		Tool compensation memory A	
Communications / Networking	USB (1 port), memory card interface, built-in Ethernet (FOCAS2/Ethernet)		
High speed/accuracy	AI contour control I, bell-shaped acceleration after cutting feed interpolation		
Energy-saving function	Idling Stop		

## Optional Specifications

Item	Kit specifications	Soft-K	AI contouring control II	Simultaneous 5-axis machining
Helical interpolation		●	●	●
Rigid tapping		●	●	●
Simultaneous editing of multiple programs (background)		●	●	●
Custom macros		●	●	●
Part program storage size: 512 KB (1,280 m)		●	●	●
Display of machine utilization time/No. of parts		●	●	●
Tool life management		●	●	●
Section of 5 optional languages		●	●	●
Inch/metric conversion		●	●	●
Tool offset pairs (99)		●	●	●
Machining condition selecting function		●	●	●
Machining quality level adjustment			●	
5-axis machining condition setting function			●	●
Tool offset memory C			●	●
Jerk control			●	●
AI contour control II			●	●
High-speed processing			●	●
Nano smoothing			●	
Smooth TCP			●	
High-speed smooth TCP				●
Data server explorer connection			●	●
Data server (including hard set) (1 GB)			●	●

Programming	
Part program storage size	1 MB (2,560 m), 2 MB (5,120 m) 4 MB (10,240 m), 8 MB (20,480 m)
Number of registerable programs (expansion programs)	Expansion 1 (1,000), expansion 2 (2,000), expansion 2 (4,000)
Tool offset pairs	200, 400, 499, 999, 2,000
Addition of custom macro common variables	Totals: 600, or 1,600
Data server size	1 GB, 4 GB
Look-ahead blocks expansion	1,000 blocks
Optional chamfering/corner R FANUC	
Programmable mirror image	
Addition of workpiece coordinate system	48 pairs, 300 pairs
Automatic corner override	
Scaling	
FS15 program format	
Tool offset	
3D tool compensation	MILLAC 800VH (Standard)
3D circular interpolation	
Tool length compensation in tool axis direction	
Fixture offset	Rotary table dynamic
Workpiece setting error compensation	MILLAC 800VH (Standard)
Inverse time feed	
One-digit F code feed	9 (parameter)
Cylindrical interpolation	
Polar coordinate interpolation	
Permissible spindle speed setting per tool	
Tool posture control	
Tool Center Point Rotation Manual Feed	
<b>Operating</b>	
Program restart	
Handle interruption	
Warming up function	
<b>Monitoring</b>	
Hour meters	Power ON, spindle running, NC ON, cutting
Power shutoff	
<b>Interface functions</b>	
FL-net	
PROFIBUS master-slave communication	
CC-Link Remote Device function	
EtherNet/IP Scanner/Adapter function	
PROFINET IO Controller/Device function	
RS-232C interface	
<b>High-Speed / high-accuracy functions</b>	
NURBS interpolation	X-Y-Z axes
<b>Other</b>	
CNC cabinet lamp	
Circuit breaker	
LCD CF card adapter	
Program protection key switch	
External M code	4 pts, 8 pts



When using Okuma products, always read the safety precautions mentioned in the instruction manual and attached to the product.

● The specifications, illustrations, and descriptions in this brochure vary in different markets and are subject to change without notice.  
Pub.No. MILLAC VH series-E-(3a)-300 (Sep 2020)



**OKUMA Corporation**

Oguchi-cho, Niwa-gun,  
Aichi 480-0193, Japan  
TEL: +81-587-95-7825 FAX: +81-587-95-6074