

Next-Generation Robot System

STANDROID

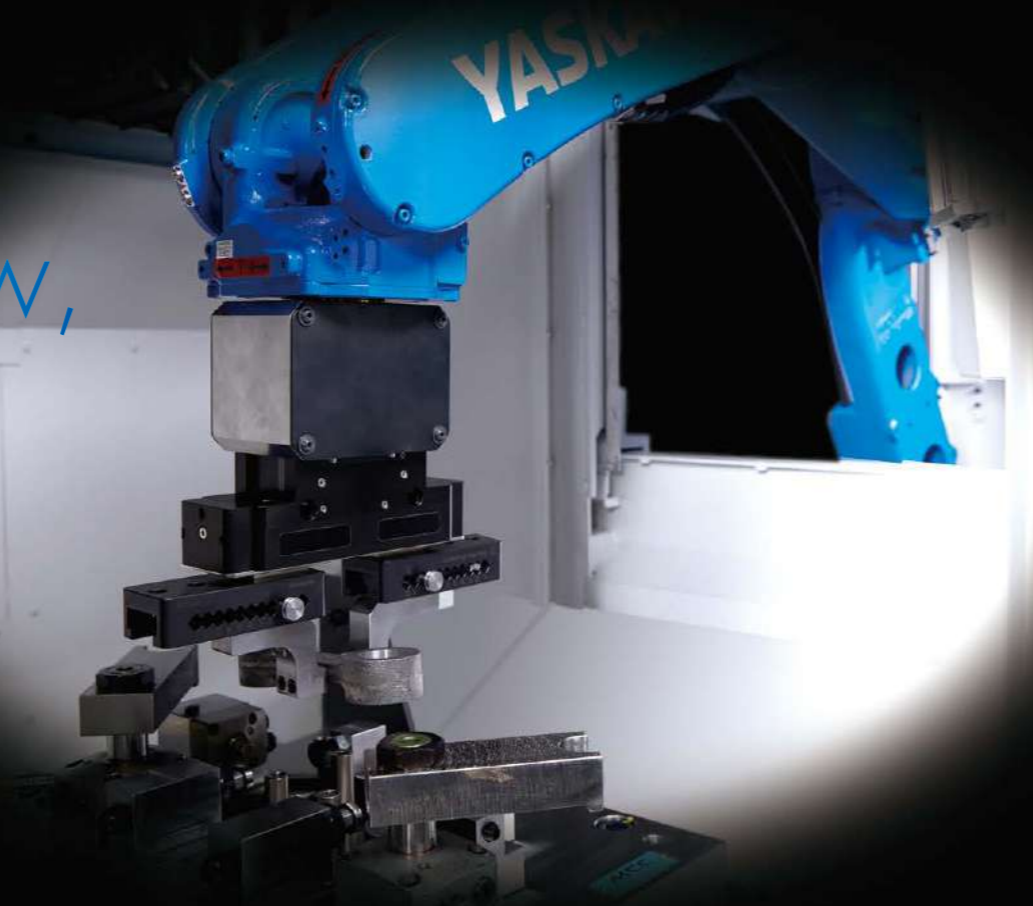

Robots for Tomorrow, Humans for Future Generations.



STANDROID, a simplified robot package that provides automation in high-mix low-/medium-volume production (HML/MV). This next-generation robot system can fundamentally change the various issues facing manufacturing today. STANDROID's easy robot operation and compact space are the features that have lowered the hurdles robot automation had faced until now.

In addition, it is the ease of operation with a package of functionality designed for improving the productivity of small and medium lots beyond normal part transfer arrangements. That automation will enable humans to perform higher value-added activities, and focus on future challenges.

This is what Okuma is proposing.

5 STANDROID advantages for innovative manufacturing

Point 1 Ease of use

No need for expertise in robotics or engineering system integrators

Since machine and robot are controlled by one operation panel, they can be handled as if in the same seamless mode. By just following the guidance system for motion settings, ROID Navi automatically generates the optimal robot movement path.

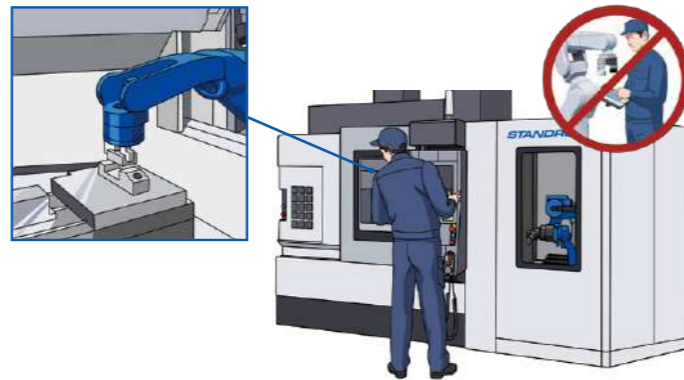

Point 2 Space

Robot footprint: About 1/2 that of conventional installations

ROID Navi automatically generates optimal robot movement paths without interference, which facilitates robot operations in 55% less than conventional space requirements. With the robot mounted to the side, it does not interfere with the operator's work.

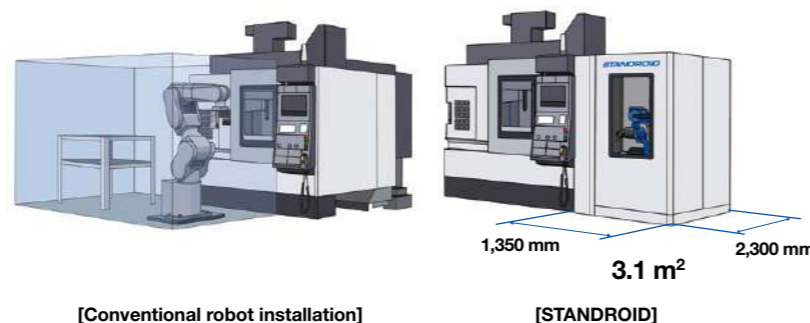

Point 3 Quick startup

Easy one-day setup

The robot and workpiece stocker are integrated in a compact package. Installation or relocation are easily done "package" setups—wiring included. After installation, you can start operation immediately with the easy-to-use ROID Navi.



Point 4 Flexibility

Package variations available for diverse production applications

A pushcart workpiece stocker is the standard package, and multi-piece stockers or air blast stations suited to the production application are also available.

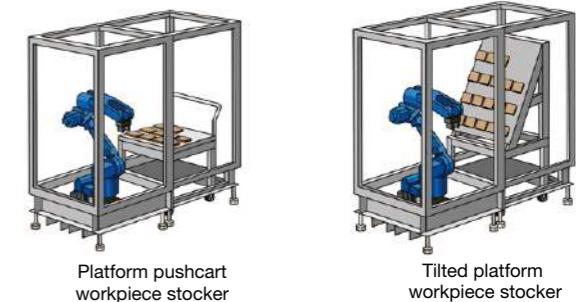

Point 5 Lower costs

Lower investment and running costs and higher ROI

Because system integrators not required, setup costs and time are reduced drastically. Since setup changes can be handled in-house, to save time and reduce costs.

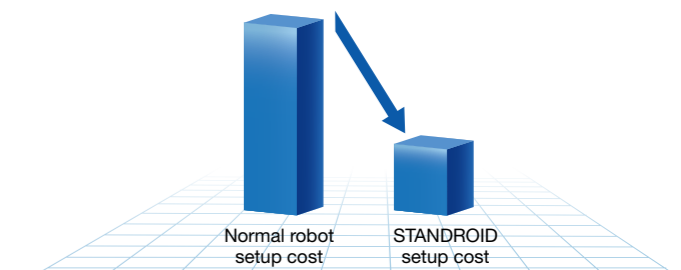

Innovations brought on by...

packaged robots

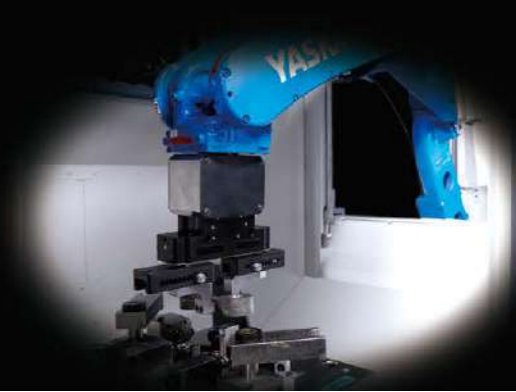

Being simple

Robot motion paths are automatically generated by Okuma's ROID Navi, a navigator developed for machine tool operators.

Easy machine tool or robot operation—by any operator

Okuma's intelligent machine tool CNC enables real time gesture control of both the robot and machine tool.

Ease of use

With the pulse handle of the machine tool, fine adjustment of the robot position can be easily performed.



ROID Navi EZ Operating Tool

The robot's motion program automatically creates an optimal, collision-free motion path, simply by setting the motion according to the guidance system. Even beginners in robotics can learn the ropes to operate from day one.

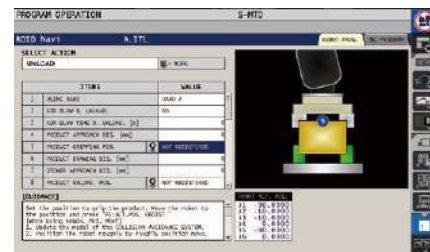

Machine operation



Robot operation



With simple operation settings, the robot operates in an optimal route in a compact space.

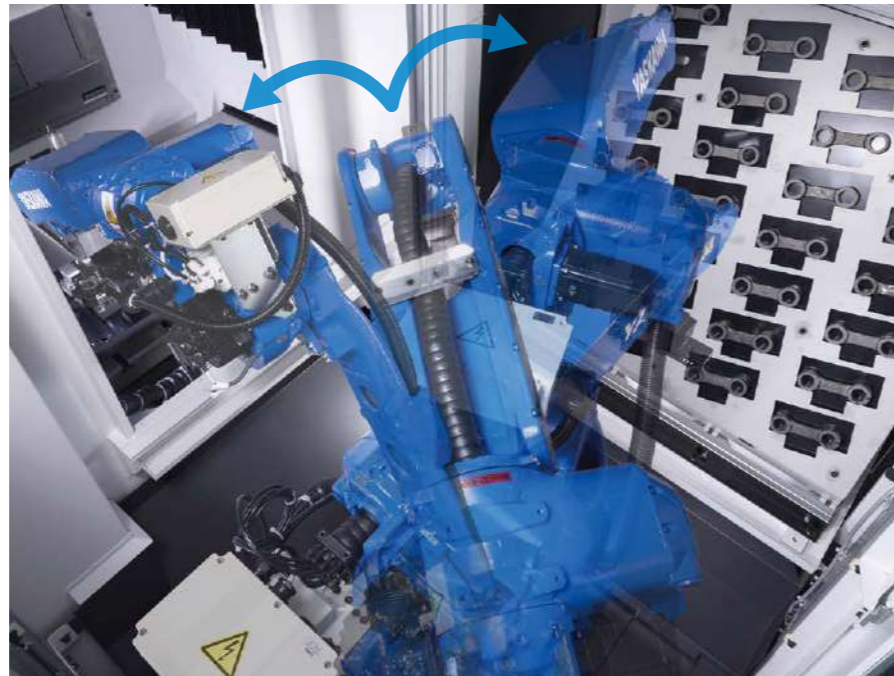

Ready for quick startups

Easy installation with systems packaged for production. Automated systems ready to go in as little as one day.

One day from installation to operation start-up

STANDROID operates in three easy steps: positioning → installation/wiring → simple operation with ROID Navi. Of course there is no need for a system integrator. Because it is an integrated robot cell, relocation with a forklift is also possible.

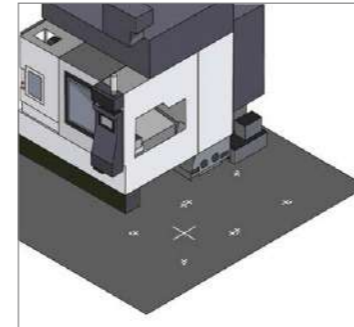

Installation positioning

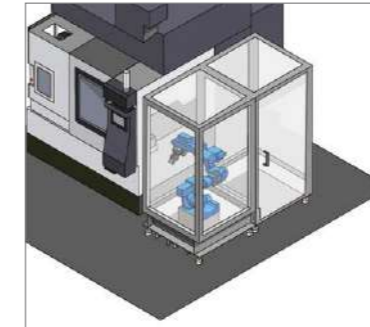

STANDROID setup leveling and anchoring



Easy robot operation with ROID Navi, an easy operation tool

How to be multifunctional

A variety of packaged units are ready, to help build high-performance automation systems.

Package units that greatly expand the range of possible applications.

Many package units have been designed to meet the workpiece, lot size, scope of automation, and other production requirements. Package units can be selected according to the production mode, and an optimal automated system can be built.



Robot + cart (flat)

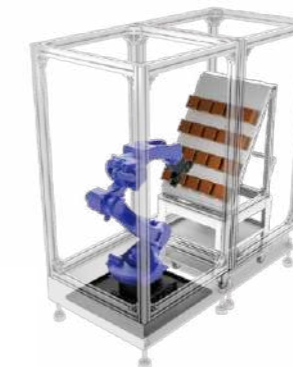

Robot + cart (tilted)



A dedicated fixture attached to the tilted cart.

Robot packages that are changing shop floor environments

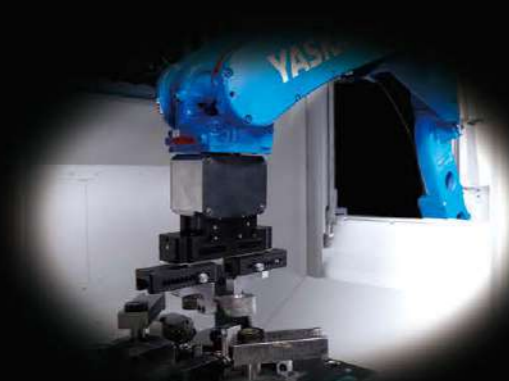

With robot packages, automated vertical machining centers will be easy to install

Applicable Models	Vertical Machining Centers	MB-46V, MB-56V, GENOS M460-V, GENOS M560-V
	5-Axis Vertical Machining Centers	MU-4000V, MU-S600V

5-Axis Vertical Machining Center + EZ Robot Package
MU-4000V-L STANDROID



19-in operation panel screen

5-Axis Vertical Machining Center + EZ Robot Package
MU-S600V STANDROID



Vertical Machining Center + EZ Robot Package
GENOS M560-V STANDROID



Expansion Packages

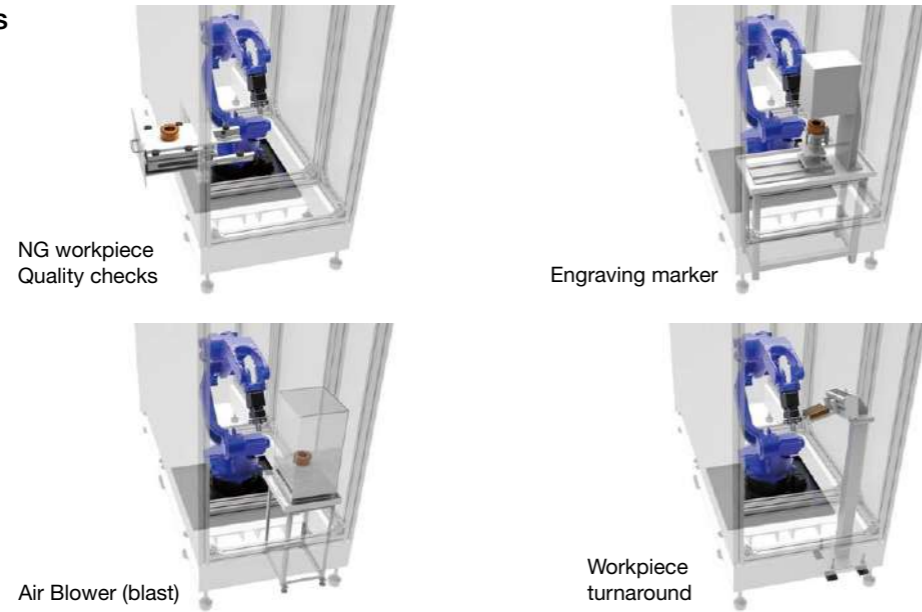

STANDROID Arm Moving Range (MOTOMAN-GP25)

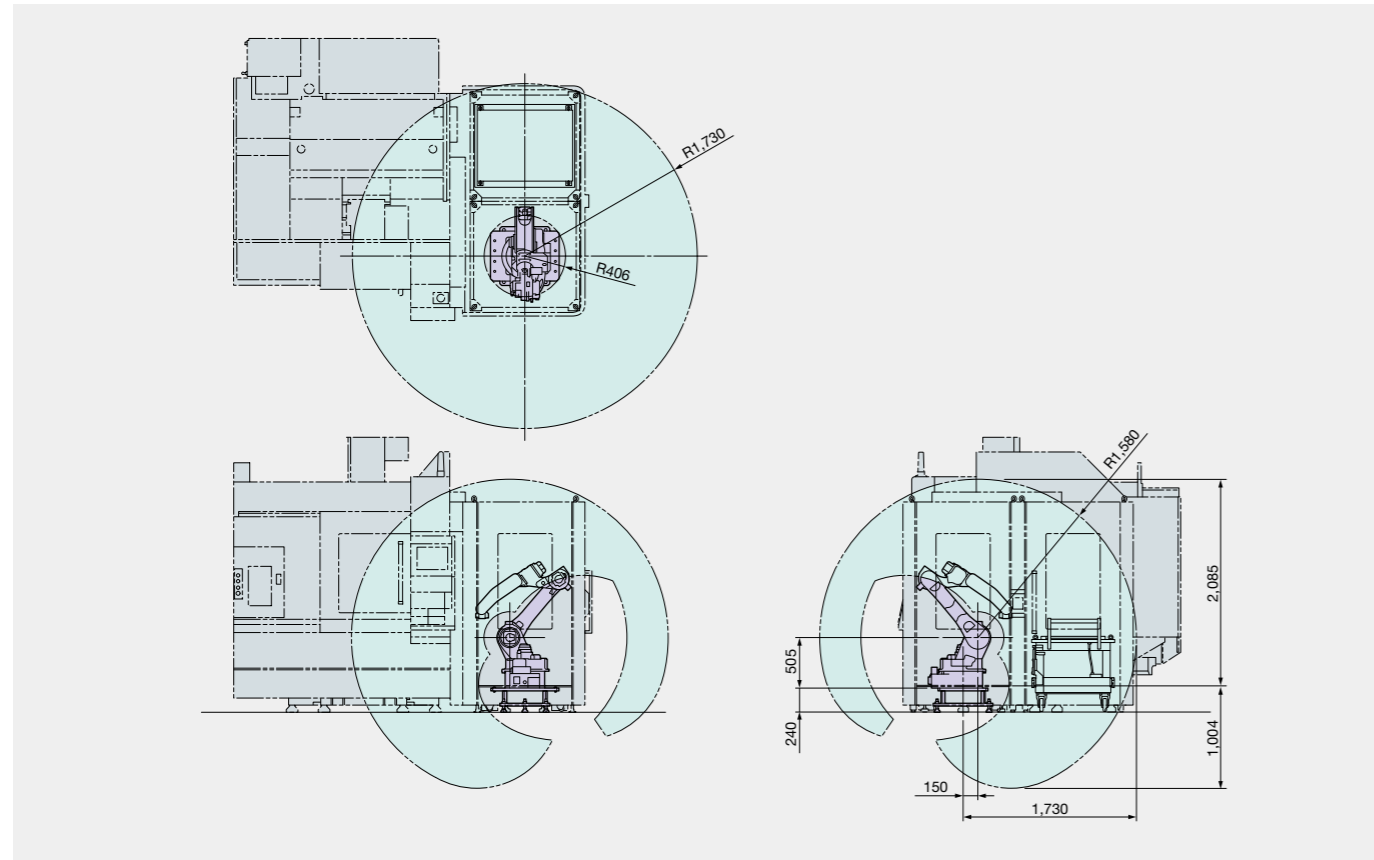

STANDROID Specifications

Applicable machine models	MB-46V, MB-56V, GENOS M460-VE, GENOS M560-V, MU-4000V, MU-S600V		
Robot	Manufacturer	Yasukawa Electric	
	Model	MOTOMAN-GP12 (MB-46V only)	MOTOMAN-GP25
Work hands	Parallel double grippers (single hand, double hand)		
Part load capacity	Single hand	5 kg	10 kg
	Double hand	2.5 kg	5 kg
Workpiece stocker	Mobile units	Flat: 700 x 950 mm (workpiece stocker surface size)	
		Tilted: 950 x 950 mm (workpiece stocker surface size)	
Expansion packages	Air blower and quality check stations, engraving marker, NG workpiece station, workpiece turnaround		

Note: Please check with engineering for workpiece handling capability and the availability of each required specification.

MB-46VAE STANDROID Dimensional / Installation Drawings

Unit: mm (in)

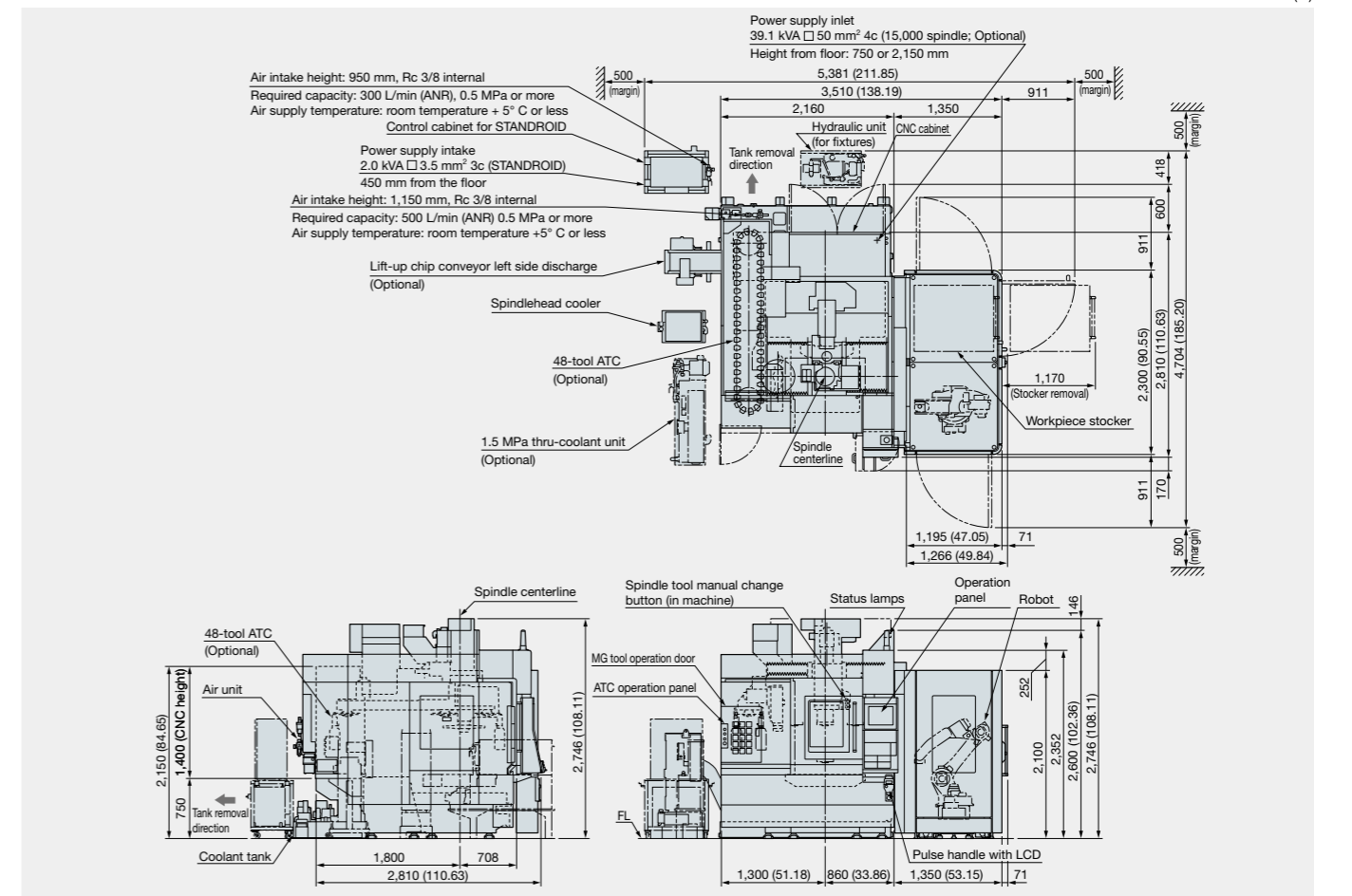

GENOS M-560-V STANDROID Dimensional / Installation Drawings

Unit: mm (in)

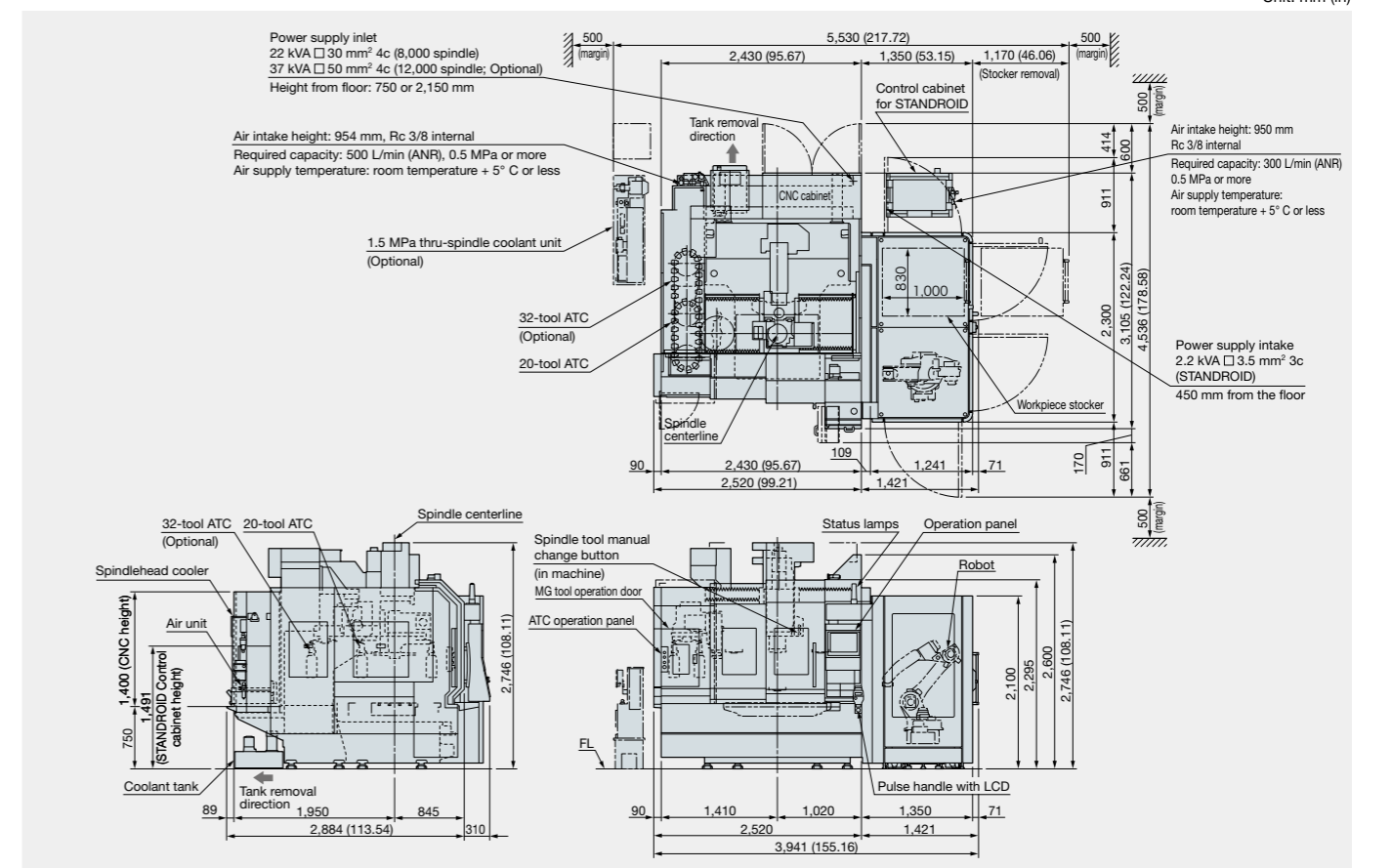

MU-4000V-L STANDROID Dimensional / Installation Drawings

Unit: mm (in)

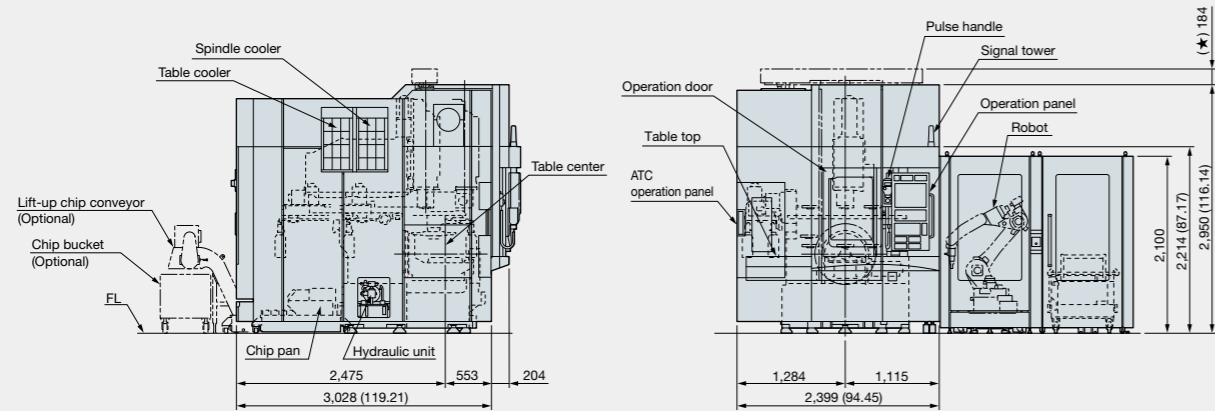
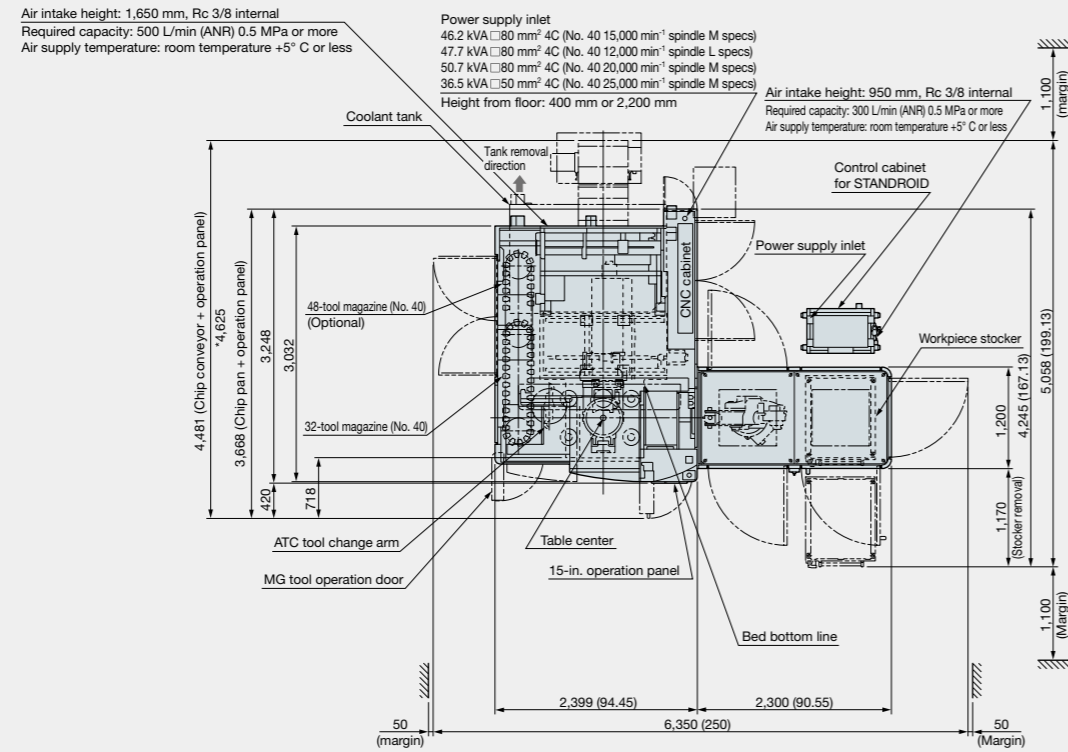

* Floor lift-up chip conveyor height: 750 mm (Optional)
 ★ Rotary wiper, auto open/close door (Optional)

MU-S600V (single machine) STANDROID Dimensional / Installation Drawings

Unit: mm (in)

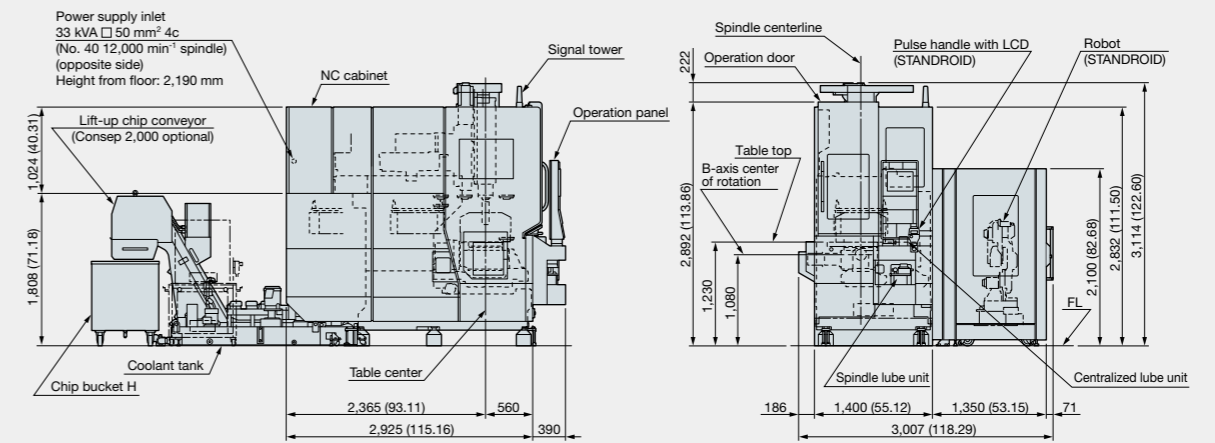
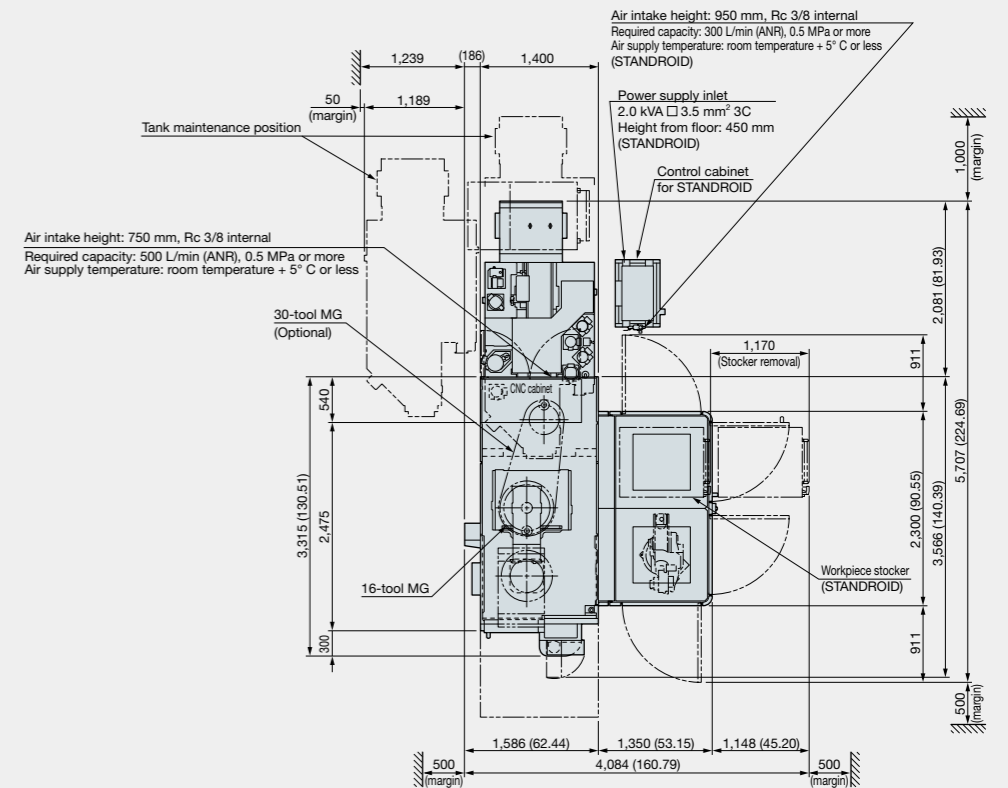

When using Okuma products, always read the safety precautions mentioned in the instruction manual and attached to the product.

●The specifications, illustrations, and descriptions in this brochure vary in different markets and are subject to change without notice.
Pub No. STANDROID-E-(3b)-500 (Nov 2019)

Note: Japan's Industrial Safety and Health Act requires that workers who "teach" industrial robots and perform inspections be required to receive special education for their work-related safety and/or health. Safety educational training should be conducted in countries other than Japan in accordance with similar laws and regulations.



OKUMA Corporation

Oguchi-cho, Niwa-gun,
Aichi 480-0193, Japan
TEL: +81-587-95-7825 FAX: +81-587-95-6074

This product is subject to the Japanese government Foreign Exchange and Foreign Trade Control Act with regard to security controlled items; whereby Okuma Corporation should be notified prior to its shipment to another country.